

#### Montering - Mounting - Montage

mm (inch)

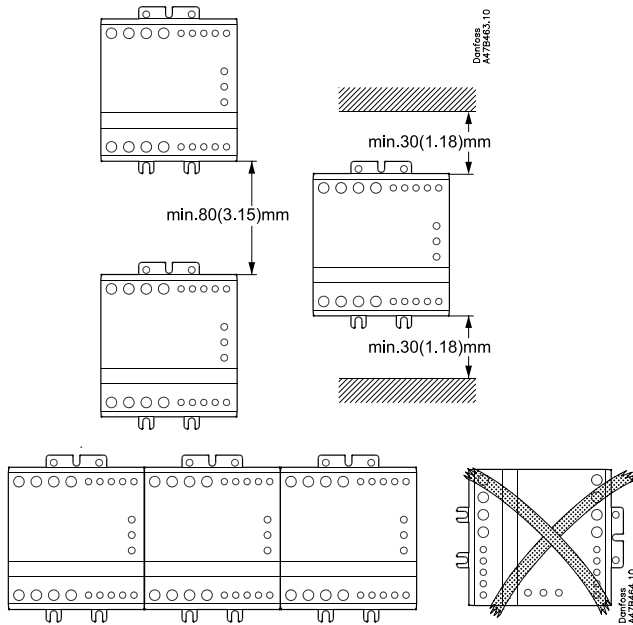

DK Hvis enhed er monteret vandret reducer strøm med 50%  
 UK If unit is mounted horizontally derate current by 50%  
 D Falls Einheit horizontal montiert wird, reduziert sich der Strom um 50%.

#### Mål - Dimensions - Abmessungen

mm (inch)

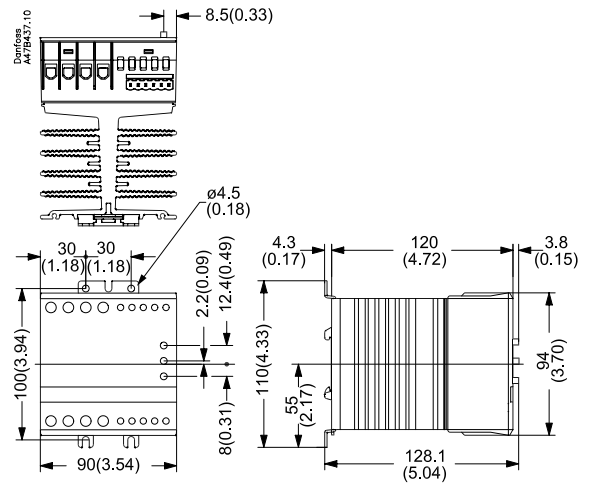

DK Køleplade skal holdes ren. Luftstrøm må ikke blokeres  
 UK Keep heat sink clean. Airflow should not be blocked  
 D Kühlfächen freihalten. Luftstrom muß ungehindert fließen

#### Forbindelse - Wiring - Verdrattung

75°C Kabel/ Wire*	mm <sup>2</sup> (AWG)	mm <sup>2</sup> (AWG)
**	1.5 - 6 (16 - 10)	0.5 - 1.5 (20 - 16)
	2 x 1.5 - 6 (2 x 16 - 10)	2 x 0.5 - 0.75 (2 x 20 - 18)
**	1.5 - 6 (16 - 10)	0.5 - 1.5 (20 - 16)
	2 x 1.5 - 6 (2 x 16 - 10)	2 x 0.5 - 1.5 (2 x 20 - 16)
**	1 - 10 (18 - 8)	0.5 - 1.5 (20 - 16)
	2 x 1 - 6 (2 x 18 - 16)	2 x 0.5 - 1.5 (2 x 20 - 16)
	Pozidrive 2 1.2 Nm max. 10.6 lb-in max.	N.A.
	6 mm 1.2 Nm max. 10.6 lb-in max.	3 mm 0.5 Nm max. 4.4 lb-in max.

- **Vigtigt:** (Overhold max. skruedrejningsmomenter)
- **Important:** (Observe the maximum screw torque limits)
- **Wichtig:** (Max. Drehmoment beachten)
- \* Use copper conductor only
- \*\* UL tested

Use UL listed magnetic circuit breaker or UL specified back-up fuse type K5 or H class

Motor A	Danfoss CTI 25
0.63 - 1.00	047B3024
1.00 - 1.63	047B3025
1.6 - 2.5	047B3026
2.5 - 4.0	047B3027
4.0 - 6.3	047B3028
6 - 10	047B3029
10 - 16	047B3030
16 - 20	047B3031
20 - 25	047B3032

Control Voltage A1-A2  
 24 - 480 VAC/DC  
 24 - 300 VAC/DC (UL)

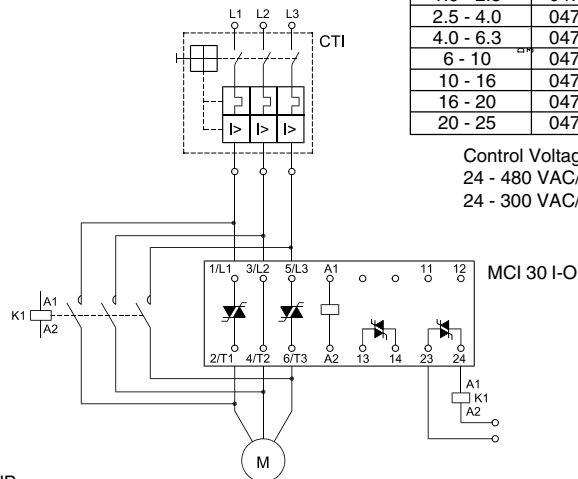

NB:  
 DK Hvis beskyttet med sikringer, se specifikationer i datablad  
 UK If protection with fuses, see recommendations in data sheet  
 D Falls Sicherungen verwendet werden, Empfehlungen im Datenblatt beachten

PS: This product has been designed for class A equipment. Use of the product in domestic environment may cause radio interference, in which case the user may be required to employ additional mitigation methods.



UL: Use thermal overload protection as required by the National Electric Code  
 UL: When protected by a non-time delay K5 or H Class fuse, rated 266% of motor FLA, this device is rated for use on a circuit capable of delivering not more than 5,000 rms. symmetrical amperes, 600 V maximum. Maximum surrounding temperature 40°C

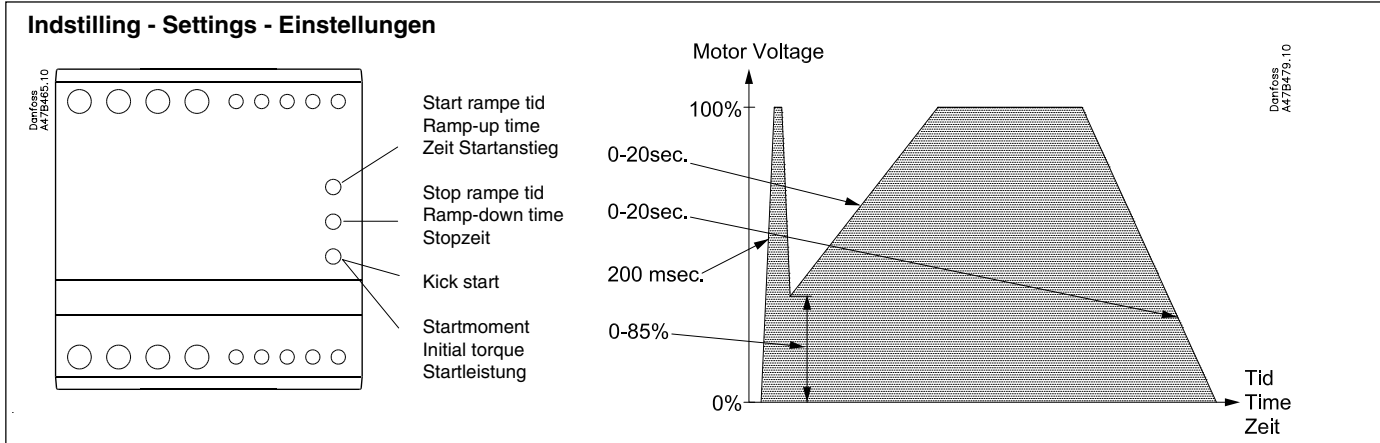

### Bemærkninger - Remarks - Bemerkungen

	Dansk	English	Deutsch
<b>NB!</b>	<ul style="list-style-type: none"> <li>Anvend 2 mm x 0.5 mm skruetrækker.</li> <li>Vær forsigtig ikke at indstille drejekontakterne imellem klik.</li> <li>Motor Controlleren aflæser tid og moment justeringen i stop tilstand.</li> <li>Gentagne starter kan resultere i at motoroverbelastningsrelæ aktiveres.</li> </ul>	<ul style="list-style-type: none"> <li>Use 2 mm x 0.5 mm screwdriver.</li> <li>Make sure that the switches click into position, otherwise time and torque settings will not be correct.</li> <li>The motor controller will read time and torque settings in the off state.</li> <li>Repeated starts may trip motor protection relay.</li> </ul>	<ul style="list-style-type: none"> <li>Schraubenzieher 2 mm x 0.5 mm verwenden.</li> <li>Schalter müssen einrasten, um korrekte Funktion zu gewährleisten.</li> <li>Eingestellte Werte werden im ausgeschalteten Zustand abgelesen.</li> <li>Mehrfache Starts können Motorschutzrelais auslösen.</li> </ul>

### Startmoment indstilling - Initial torque setting - Einstellung der Startleistung

	Dansk	English	Deutsch
	<ol style="list-style-type: none"> <li>Indstil <b>Ramp-up</b> kontakt til max.</li> <li>indstil <b>Ramp-down</b> kontakt til min.</li> <li>Indstil <b>Initial Torque</b> kontakt til min.</li> <li>Påtryk signalspænding i et par sekunder, hvis ikke motorakslen roterer øjeblikkelig efter start juster <b>Initial torque</b> en deling op. Gentag indtil motorakslen roterer øjeblikkelig efter start.</li> </ol>	<ol style="list-style-type: none"> <li>Set <b>Ramp-up</b> switch to max.</li> <li>Set <b>Ramp-down</b> switch to min.</li> <li>Set <b>Initial torque</b> switch to min.</li> <li>Apply control signal for a few seconds. If the load does not rotate immediately increase the <b>Initial torque</b> for one step and try again. Repeat until the load starts to rotate immediately on start up.</li> </ol>	<ol style="list-style-type: none"> <li><b>Ramp-up</b> Schalter auf max. stellen</li> <li><b>Ramp-down</b> Schalter auf min. stellen</li> <li><b>Initial torque</b> Schalter auf min. stellen</li> <li>Steuersignal einige Sekunden betätigen. Falls der Motor nicht sofort anläuft <b>Initial torque</b> schrittweise erhöhen, bis der Motor anläuft.</li> </ol>
	<p>Hvis <b>Initial torque</b> justeringen ikke er tilstrækkelig til at starte motoren, er det nødvendigt at anvende <b>Kick-start</b>.</p> <ol style="list-style-type: none"> <li>Indstil <b>Ramp-up</b> tiden til max.</li> <li>Indstil <b>Ramp-down</b> tiden til min.</li> <li>Indstil <b>Initial torque</b> til minimum <b>kick-start</b> moment.</li> <li>Påtryk signalspænding i et par sekunder. Hvis belastningen stopper umiddelbart efter <b>Kick-start</b> perioden juster <b>Initial torque</b> en deling op. Gentag indtil motorakslen fortsætter med at rotere efter <b>Kick-start</b> perioden.</li> </ol>	<p>If the maximum <b>Initial torque</b> setting is not sufficient to start the motor, it is necessary to use <b>Kick-start</b></p> <ol style="list-style-type: none"> <li>Set <b>Ramp-up</b> switch to max.</li> <li>Set <b>Ramp-down</b> switch to min.</li> <li>Set <b>Initial torque</b> switch to min. <b>kick start</b> torque.</li> <li>Apply control signal for a few seconds. If the load stops right after the <b>kick start</b> increase the <b>Initial torque</b> for one step and try again. Repeat until the load continues to rotate after the "kick".</li> </ol>	<p>Falls <b>Initial torque</b> max. Einstellung nicht ausreichend um den Motor zu starten, muß <b>Kick-start</b> verwendet werden.</p> <ol style="list-style-type: none"> <li><b>Ramp-up</b> Schalter auf max. stellen</li> <li><b>Ramp-down</b> Schalter auf min. stellen</li> <li><b>Initial torque</b> Schalter auf min. <b>Kick-start</b> stellen.</li> <li>Steuersignal einige Sekunden betätigen. Falls der Motor sofort wieder stoppt, <b>Initial torque</b> schrittweise erhöhen, bis der Motor sofort nach dem "Kick" anläuft.</li> </ol>

### Start rampe indstilling - Ramp up settings - Einstellung der Startanstiegszeit

	Dansk	English	Deutsch
	<ol style="list-style-type: none"> <li>Indstil <b>Ramp-up</b> tiden til max. og start motor.</li> <li>Gradvis nedsæt <b>Ramp-up</b> tiden indtil motor og belastning netop overbelastes.</li> <li>Juster <b>Ramp-up</b> tiden en deling op.</li> </ol>	<ol style="list-style-type: none"> <li>Set <b>Ramp-up</b> switch to max. and start motor.</li> <li>Decrease the <b>Ramp-up</b> time until mechanical surge is observed.</li> <li>Increase <b>Ramp-up</b> time one step.</li> </ol>	<ol style="list-style-type: none"> <li><b>Ramp-up</b> Schalter auf max. stellen.</li> <li><b>Ramp-up</b> Zeit solange verkürzen bis Überbelastung beobachtet wird.</li> <li><b>Ramp-up</b> Zeit um einen Schritt erhöhen.</li> </ol>

### Stop rampe indstilling - Ramp down settings - Einstellung der Startanstiegszeit

	Dansk	English	Deutsch
	<ol style="list-style-type: none"> <li>Indstil <b>Ramp-down</b> tiden til max. og afbryd signalspændingen.</li> <li>Gradvis nedsæt <b>Ramp-down</b> tiden indtil motor og belastning netop overbelastes.</li> <li>Juster <b>Ramp-down</b> tiden en deling op.</li> </ol>	<ol style="list-style-type: none"> <li>Set <b>Ramp-down</b> switch to max. and switch off the control voltage.</li> <li>Decrease the <b>Ramp-down</b> time until mechanical surge is observed.</li> <li>Increase <b>Ramp-down</b> time one step.</li> </ol>	<ol style="list-style-type: none"> <li><b>Ramp-down</b> Schalter auf max. stellen und Steuersignal ausschalten.</li> <li><b>Ramp-down</b> Zeit solange verkürzen bis Überbelastung beobachtet wird.</li> <li><b>Ramp-down</b> Zeit um einen Schritt erhöhen.</li> </ol>