

Soft start motor controller MCI 40-3D I-O

Montering - Mounting - Montage

mm (inch)

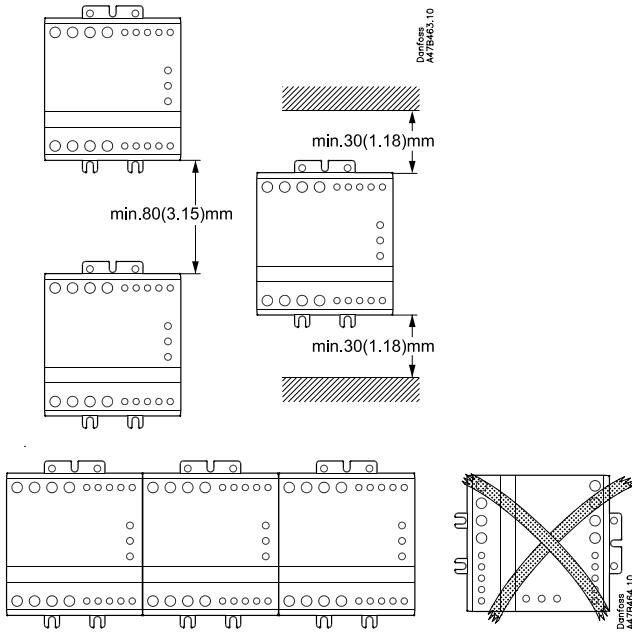

DK Hvis enhed er monteret vandret reducer strøm med 50%
 UK If unit is mounted horizontally derate current by 50%
 D Falls Einheit horizontal montiert wird, reduziert sich der Strom um 50%.

Mål - Dimensions - Abmessungen

mm (inch)

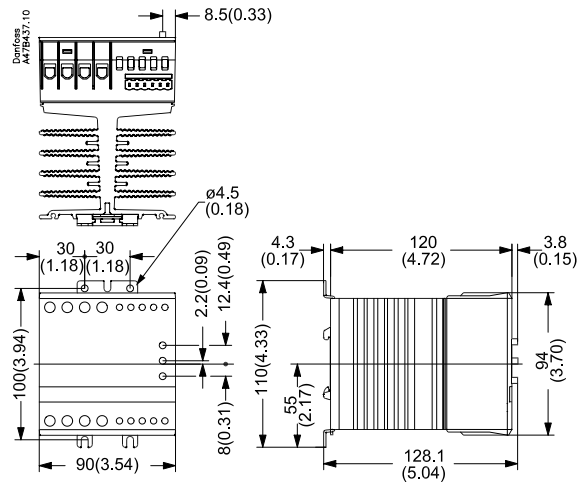

DK Køleplade skal holdes ren. Luftstrøm må ikke blokeres
 UK Keep heat sink clean. Airflow should not be blocked
 D Kühlflächen freihalten. Luftstrom muß ungehindert fließen

Forbindelse - Wiring - Verdrahtung

75°C Kabel/ Wire*	mm ² (AWG)	mm ² (AWG)
**	1.5 - 6 (16 - 10)	0.5 - 1.5 (20 - 16)
	2 x 1.5 - 6 (2 x 16 - 10)	2 x 0.5 - 0.75 (2 x 20 - 18)
**	1.5 - 6 (16 - 10)	0.5 - 1.5 (20 - 16)
	2 x 1.5 - 6 (2 x 16 - 10)	2 x 0.5 - 1.5 (2 x 20 - 16)
**	1 - 10 (18 - 8)	0.5 - 1.5 (20 - 16)
	2 x 1 - 6 (2 x 18 - 16)	2 x 0.5 - 1.5 (2 x 20 - 16)
	Pozidrive 2 1.2 Nm max. 10.6 lb-in max.	N.A.
	6 mm 1.2 Nm max. 10.6 lb-in max.	3 mm 0.5 Nm max. 4.4 lb-in max.

- **Vigtigt:** (Overhold max. skruedrejningsmomenter)
 - **Important:** (Observe the maximum screw torque limits)
 - **Wichtig:** (Max. Drehmoment beachten)
 * Use copper conductor only
 ** UL tested

Use UL listed magnetic circuit breaker or UL specified back-up fuse type K5 or H class

Motor A	Danfoss CTI
0.63 - 2.5	047B3153
2.5 - 4.0	047B3154
4.0 - 6.3	047B3155
6.3 - 10	047B3156
10 - 16	047B3157
14.5 - 20	047B3158
18 - 25	047B3159
23 - 32	047B3164
23 - 45	047B3165

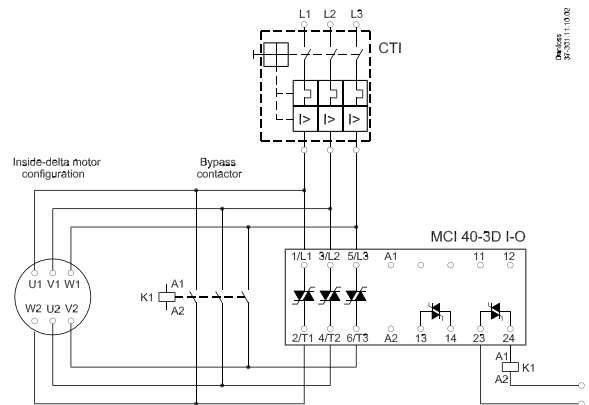

NB:
 DK Hvis beskyttet med sikringer, se specifikationer i datablad
 UK If protection with fuses, see recommendations in data sheet
 D Falls Sicherungen verwendet werden, Empfehlungen im Datenblatt beachten
 PS: This product has been designed for class A equipment. Use of the product in domestic environment may cause radio interference, in which case the user may be required to employ additional mitigation methods.



UL: Use thermal overload protection as required by the National Electric Code
 UL: When protected by a non-time delay K5 or H Class fuse, rated 266% of motor FLA, this device is rated for use on a circuit capable of delivering not more than 5,000 rms. symmetrical amperes, 600 V maximum. Maximum surrounding temperature 40°C

Soft start motor controller MCI 40-3D I-O

Indstilling - Settings - Einstellungen

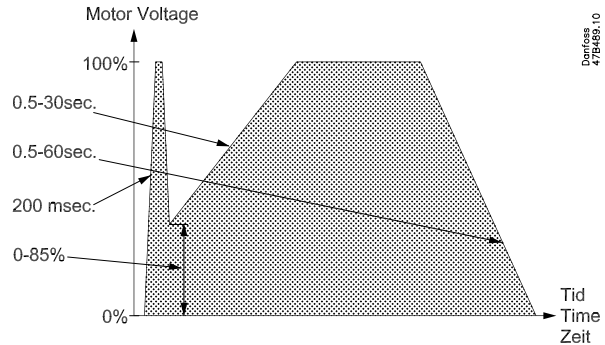
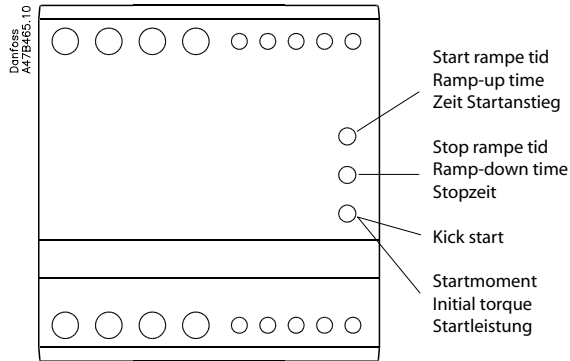

Bemærkninger - Remarks - Bemerkungen

	Dansk	English	Deutsch
NB!	<ul style="list-style-type: none"> Anvend 2 mm x 0.5 mm skruetrækker. Vær forsigtig ikke at indstille drejekontakterne imellem klik. Motor Controlleren aflæser tid og momentjusteringen i stop tilstand. Gentagne starter kan resultere i at motoroverbelastningsrelæ aktiveres. 	<ul style="list-style-type: none"> Use 2 mm x 0.5 mm screwdriver. Make sure that the switches click into position, otherwise time and torque settings will not be correct. The motor controller will read time and torque settings in the off state. Repeated starts may trip motor protection relay. 	<ul style="list-style-type: none"> Schraubenzieher 2 mm x 0.5 mm verwenden. Schalter müssen einrasten, um korrekte Funktion zu gewährleisten. Eingestellte Werte werden im ausgeschalteten Zustand abgelesen. Mehrfache Starts können Motorschutzrelais auslösen,

Startmoment indstilling - Initial torque setting - Einstellung der Startleistung

	Dansk	English	Deutsch
	<ol style="list-style-type: none"> Indstil Ramp-up kontakt til max. Indstil Ramp-down kontakt til min. Indstil Initial Torque kontakt til min. Påtryk signalspænding i et par sekunder, hvis ikke motorakslen roterer øjeblikkelig efter start juster Initial torque en deling op. Gentag indtil motoraksel roterer øjeblikkelig efter start. 	<ol style="list-style-type: none"> Set Ramp-up switch to max. Set Ramp-down switch to min. Set Initial torque switch to min. Apply control signal for a few seconds. If the load does not rotate immediately increase the Initial torque for one step and try again. Repeat until the load starts to rotate immediately on start up. 	<ol style="list-style-type: none"> Ramp-up Schalter auf max. stellen Ramp-down Schalter auf min. stellen Initial torque Schalter auf min. stellen Steuersignal einige Sekunden betätigen. Falls der Motor nicht sofort anläuft Initial torque schrittweise erhöhen, bis der Motor anläuft.
	<p>Hvis Initial torque justeringen ikke er tilstrækkeligt til at starte motoren, er det nødvendigt at anvende Kick-start.</p> <ol style="list-style-type: none"> Indstil Ramp-up tiden til max. Indstil Ramp-down tiden til min. Indstil Initial torque til minimum kick-start moment. Påtryk signalspænding i et par sekunder. Hvis belastningen stopper umiddelbart efter Kick-start perioden juster Initial torque en deling op. Gentag indtil motoraksel fortsætter med at rotere efter Kick-start perioden. 	<p>If the maximum Initial torque setting is not sufficient to start the motor, it is necessary to use Kick-start</p> <ol style="list-style-type: none"> Set Ramp-up switch to max. Set Ramp-down switch to min. Set Initial torque switch to min. kick start torque. Apply control signal for a few seconds. If the load stops right after the kick start increase the Initial torque for one step and try again. Repeat until the load continues to rotate after the "kick". 	<p>Falls Initial torque max. Einstellung nicht ausreicht um den Motor zu starten, muß Kick-start verwendet werden.</p> <ol style="list-style-type: none"> Ramp-up Schalter auf max. stellen Ramp-down Schalter auf min. stellen Initial torque Schalter auf min. Kick-start stellen. Steuersignal einige Sekunden betätigen. Falls der Motor sofort wieder stoppt, initial torque schrittweise erhöhen, bis der Motor sofort nach dem "Kick" anläuft.

Start rampe indstilling - Ramp up settings - Einstellung der Startanstiegszeit

	Dansk	English	Deutsch
	<ol style="list-style-type: none"> Indstil Ramp-up tiden til max. og start Gradvis nedsæt Ramp-up tiden indtil motor og belastning netop overbelastes. Juster Ramp-up tiden en deling op. 	<ol style="list-style-type: none"> Set Ramp-up switch to max. and start motor. Decrease the Ramp-up time until mechanical surge is observed. Increase Ramp-up time one step. 	<ol style="list-style-type: none"> Ramp-up Schalter auf max. stellen. Ramp-up Zeit solange verkürzen bis Überbelastung beobachtet wird. Ramp-up Zeit um einen Schritt erhöhen

Stop rampe indstilling - Ramp down settings - Einstellung der Startanstiegszeit

	Dansk	English	Deutsch
	<ol style="list-style-type: none"> Indstil Ramp-down tiden til max. og afbryd signalspændingen. Gradvis nedsæt Ramp-down tiden indtil motor og belastning netop overbelastes. Juster Ramp-down tiden en deling op. 	<ol style="list-style-type: none"> Set Ramp-down switch to max. and switch off the control voltage Decrease the Ramp-down time until mechanical surge is observed. Increase Ramp-up time one step. 	<ol style="list-style-type: none"> Ramp-down Schalter auf max. stellen und Steuersignal ausschalten. Ramp-down Zeit solange verkürzen bis Überbelastung beobachtet wird. Ramp-down Zeit um einen Schritt erhöhen.