

NL10MF

Standard Compressor

R134a

220-240V 50Hz & 208-230V 60Hz

General

Code number	105G6886
Approvals	EN 60335-2-34, UL984
Compressors on pallet	80

Application

Application	MBP			
	Hz	50	60	
Frequency	Hz	50	60	
Evaporating temperature	°C	-20 to 15	-35 to 7.2	
Voltage range	V	187 - 254	198 - 254	
Max. condensing temperature continuous (short)	°C	60 (70)	60 (70)	
Max. winding temperature continuous (short)	°C	125 (135)	125 (135)	

Cooling requirements

Frequency	Hz	50			60		
		LBP	MBP	HBP	LBP	MBP	HBP
32°C		-	F ₁	F ₁	F ₁	F ₁	-
38°C		-	F ₁	F ₁	F ₁	F ₁	-
43°C		-	F ₁	F ₁	F ₁	F ₁	-

Remarks on application: F₂ for 230-240V 50Hz nominal below -12°C evaporating temp. CSIR strongly recommended for 60Hz

Motor

Motor type	RSIR/CSIR		
LRA (rated after 4 sec. UL984), HST LST	A	16.1	13.1
Cut in Current, HST LST	A	16.1	17.1
Resistance, main start winding (25°C)	Ω	6.1	17.5

Design

Displacement	cm ³	10.10
Oil quantity (type)	cm ³	320 (polyolester)
Maximum refrigerant charge	g	600
Free gas volume in compressor	cm ³	2360
Weight without electrical equipment	kg	10.5

Dimensions

Height	mm	A	203
		B	197
		B1	-
		B2	-
Suction connector	location/I.D. mm angle	C	9.7 15°
	material comment	Cu-plated steel Al cap	
Process connector	location/I.D. mm angle	D	6.5 25°
	material comment	Cu-plated steel Al cap	
Discharge connector	location/I.D. mm angle	E	6.5 35°
	material comment	Cu-plated steel Al cap	
Oil cooler connector	location/I.D. mm angle	F	-
	material comment	-	
Connector tolerance	I.D. mm		±0.09
Remarks:			

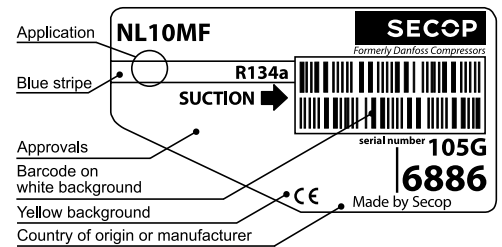

- S = Static cooling normally sufficient
- O = Oil cooling
- F₁ = Fan cooling 1.5 m/s (compressor compartment temperature equal to ambient temperature)
- F₂ = Fan cooling 3.0 m/s necessary
- SG = Suction gas cooling normally sufficient
- = not applicable in this area

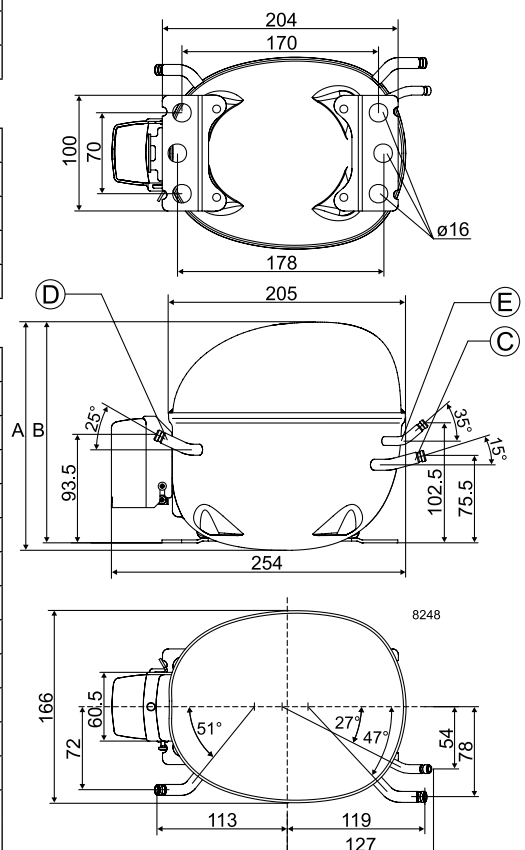

EN 12900 Household (CECOMAF) 220V, 50Hz, fan cooling F₁

Evap. temp. in °C	-45	-40	-35	-30	-25	-23.3	-20	-15	-10	-6.7	-5	0	5	7.2	10	15	20
Capacity in W							266	346	441	513	554	687	843	919	1023	1231	
Power cons. in W							251	286	323	347	360	397	435	451	472	509	
Current cons. in A							2.06	2.15	2.25	2.33	2.37	2.50	2.65	2.72	2.81	2.98	
COP in W/W							1.06	1.21	1.37	1.48	1.54	1.73	1.94	2.04	2.17	2.42	

EN 12900 Household (CECOMAF) 220V, 60Hz, fan cooling F₁

Evap. temp. in °C	-45	-40	-35	-30	-25	-23.3	-20	-15	-10	-6.7	-5	0	5	7.2	10	15	20
Capacity in W			109	166	233	258	312	406	518	603	650	807	989	1079			
Power cons. in W			143	187	232	248	278	325	373	405	421	470	518	540			
Current cons. in A			1.44	1.57	1.71	1.76	1.87	2.03	2.21	2.34	2.40	2.60	2.82	2.91			
COP in W/W			0.76	0.89	1.00	1.04	1.12	1.25	1.39	1.49	1.54	1.72	1.91	2.00			

ASHRAE MBP 220V, 50Hz, fan cooling F₁

Evap. temp. in °C	-45	-40	-35	-30	-25	-23.3	-20	-15	-10	-6.7	-5	0	5	7.2	10	15	20
Capacity in W							293	382	487	567	611	758	930	1014	1129	1359	
Power cons. in W							251	286	322	346	358	396	433	449	470	506	
Current cons. in A							2.06	2.15	2.25	2.33	2.37	2.50	2.64	2.71	2.81	2.90	
COP in W/W							1.17	1.33	1.51	1.64	1.71	1.92	2.15	2.26	2.40	2.68	

ASHRAE MBP 220V, 60Hz, fan cooling F₁

Evap. temp. in °C	-45	-40	-35	-30	-25	-23.3	-20	-15	-10	-6.7	-5	0	5	7.2	10	15	20
Capacity in W			122	184	258	285	344	448	571	665	718	890	1092	1190			
Power cons. in W			144	188	232	248	278	325	372	403	419	467	515	536			
Current cons. in A			1.44	1.57	1.71	1.76	1.87	2.03	2.21	2.33	2.39	2.59	2.81	2.90			
COP in W/W			0.84	0.98	1.11	1.15	1.24	1.38	1.53	1.65	1.71	1.90	2.12	2.22			

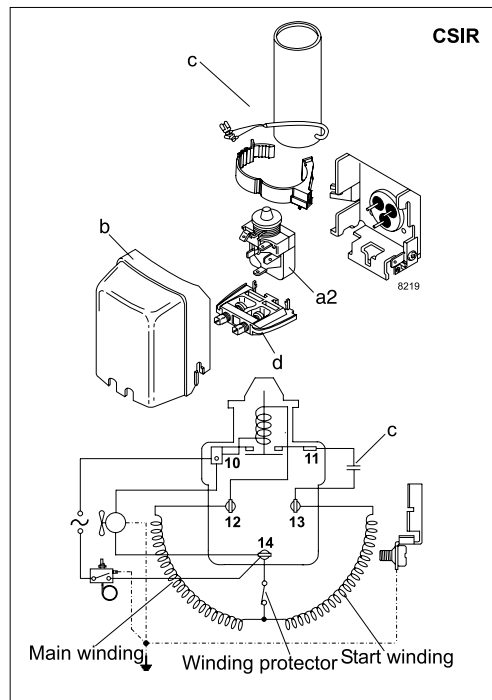
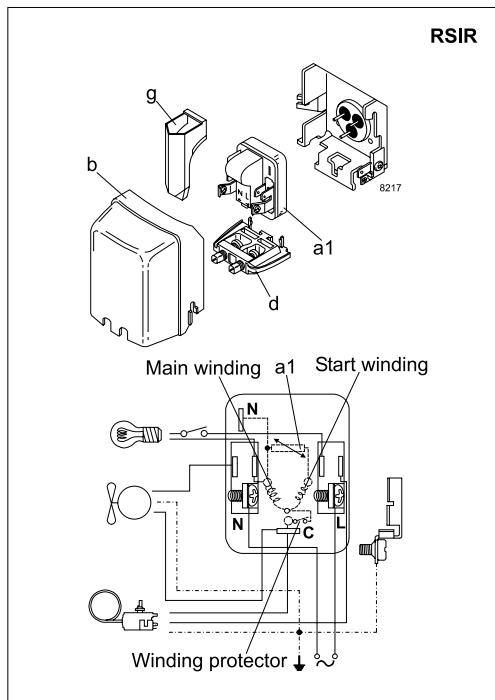

Accessories for	NL10MF	Figure	Code number
PTC starting device	6.3 mm spade connectors	a1	103N0011
	4.8 mm spade connectors		103N0018
Starting relay	6.3 mm spade connectors	a2	117U6022
Start. capacitor 125 µF	6.3 mm spade connectors	c	117U5018
Cover		b	103N2011
Cord relief		d	103N1010
Protection screen for PTC		g	103N0476

Test conditions	EN 12900/CECOMAF	ASHRAE
Condensing temperature	55°C	54.4°C
Ambient temperature	32°C	35°C
Suction gas temperature	32°C	35°C
Liquid temperature	no subcooling	46.1°C

Mounting accessories		Code number
Bolt joint for one comp.	Ø: 16 mm	118-1917
Bolt joint in quantities	Ø: 16 mm	118-1918
Snap-on in quantities	Ø: 16 mm	118-1919

Danfoss can accept no responsibility for possible errors in catalogues, brochures and other printed material. Danfoss reserves the right to alter its products without notice. This also applies to products already on order provided that such alterations can be made without subsequential changes being necessary in specifications already agreed. All trademarks in this material are property of the respective companies. Danfoss and the Danfoss logotype are trademarks of Danfoss A/S. All rights reserved.