

## GEA Bock Compressor HG12P

### Assembly instructions

HG12P/75-4  
HG12P/90-4  
HG12P/110-4

HG12P/60-4 S  
HG12P/75-4 S  
HG12P/90-4 S  
HG12P/110-4 S

HGX12P/75-4  
HGX12P/90-4  
HGX12P/110-4

HGX12P/60-4 S  
HGX12P/75-4 S  
HGX12P/90-4 S  
HGX12P/110-4 S

# About these instructions

Read these instructions before assembly and before using the compressor. This will avoid misunderstandings and prevent damage. Improper assembly and use of the compressor can result in serious or fatal injury.

Observe the safety instructions contained in these instructions.

These instructions must be passed onto the end customer along with the unit in which the compressor is installed.

## Manufacturer

GEA Bock GmbH  
72636 Frickenhausen

## Contact

GEA Bock GmbH  
Benzstraße 7  
72636 Frickenhausen  
Germany

GB

Telephone +49 7022 9454 0  
Fax +49 7022 9454 137  
refrigeration@gea.com  
www.gea.com

## Contents

Page

<b>1</b>	<b>Safety</b>	<b>4</b>
1.1	Identification of safety instructions	
1.2	Qualifications required of personnel	
1.3	General safety instructions	
1.4	Intended use	
<b>2</b>	<b>Product description</b>	<b>6</b>
2.1	Short description	
2.2	Name plate	
2.3	Type key	

<b>3</b>	<b>Areas of application</b>	<b>8</b>
3.1	Refrigerants	
3.2	Oil charge	
3.3	Limits of application	
<b>4</b>	<b>Compressor assembly</b>	<b>10</b>
4.1	Storage and transport	
4.2	Setting up	
4.3	Pipe connections	
4.4	Pipes	
4.5	Laying suction and pressure lines	
4.6	Operating the shut-off valves	
4.7	Operating mode of the lockable service connections	
<b>5</b>	<b>Electrical connection</b>	<b>13</b>
5.1	Information for contactor and motor contactor selection	
5.2	Connection of the driving motor	
5.3	Circuit diagram for direct start 230 V $\Delta$ / 400 V Y --> <b>with MP10</b>	
5.4	Electronic trigger unit MP10	
5.5	Connection of the electronic trigger unit MP10	
5.6	Functional test of the electronic trigger unit MP10	
5.7	Circuit diagram for direct start 230 V $\Delta$ / 400 V Y --> <b>with INT69 G</b>	
5.8	Electronic trigger unit INT69 G	
5.9	Connection of the electronic trigger unit INT69 G	
5.10	Functional test of the electronic trigger unit INT69 G	
<b>6</b>	<b>Commissioning</b>	<b>22</b>
6.1	Preparations for start-up	
6.2	Pressure strength test	
6.3	Leak test	
6.4	Evacuation	
6.5	Refrigerant charge	
6.6	Start-up	
6.7	Avoiding slugging	
6.8	Connection of oil level regulator	
<b>7</b>	<b>Maintenance</b>	<b>24</b>
7.1	Preparation	
7.2	Work to be carried out	
7.3	Spare parts recommendation	
7.4	Accessories	
7.5	Extract from the lubricants table	
7.6	Decommissioning	
<b>8</b>	<b>Technical data</b>	<b>26</b>
<b>9</b>	<b>Dimensions and connections</b>	<b>27</b>
<b>10</b>	<b>Declaration of conformity and installation</b>	<b>28</b>
<b>11</b>	<b>Service</b>	<b>29</b>

# 1| Safety

## 1.1 Identification of safety instructions:



**DANGER**

Indicates a dangerous situation which, if not avoided, will cause immediate fatal or serious injury.



**WARNING**

Indicates a dangerous situation which, if not avoided, may cause fatal or serious injury.



**CAUTION**

Indicates a dangerous situation which, if not avoided, may cause fairly severe or minor injury.



**ATTENTION**

Indicates a situation which, if not avoided, may cause property damage.



**INFO**

Important information or tips on simplifying work.

GB

## 1.2 Qualifications required of personnel



**WARNING**

**Inadequately qualified personnel poses the risk of accidents, the consequence being serious or fatal injury. Work on compressors is therefore reserved for personnel which is qualified to work on pressurized refrigerant systems:**

- For example, a refrigeration technician, refrigeration mechatronic engineer. As well as professions with comparable training, which enables personnel to assemble, install, maintain and repair refrigeration and air-conditioning systems. Personnel must be capable of assessing the work to be carried out and recognising any potential dangers.

# 1| Safety

## 1.3 General safety instructions



### WARNING

**Risk of accidents.**

Refrigerating compressors are pressurised machines and as such call for heightened caution and care in handling.

The maximum permissible overpressure must not be exceeded, even for testing purposes.

**Risk of burns!**

- Depending on the operating conditions, surface temperatures of over 60°C on the discharge side or below 0°C on the suction side can be reached.

- Avoid contact with refrigerant necessarily.

Contact with refrigerant can cause severe burns and skin damage.

## 1.4 Intended use



### WARNING

**The compressor may not be used in potentially explosive environments!**

GB

These assembly instructions describe the standard version of the compressor named in the title manufactured by GEA Bock. GEA Bock refrigerating compressors are intended for installation in a machine (within the EU according to the EU Directives 2006/42/EC Machinery Directive, 97/23/EC Pressure Equipment Directive and 2006/95/EC – Low Voltage Directive).

Commissioning is permissible only if the compressor has been installed in accordance with these assembly instructions and the entire system into which it is integrated has been inspected and approved in accordance with legal regulations.

The compressors are intended for use in refrigeration systems in compliance with the limits of application.

Only the refrigerant specified in these instructions may be used.

**Any other use of the compressor is prohibited!**

## 2| Product description

### 2.1 Short description

- Semi-hermetic two-cylinder reciprocating compressor with oil pump lubrication.
- Suction gas cooled drive motor.

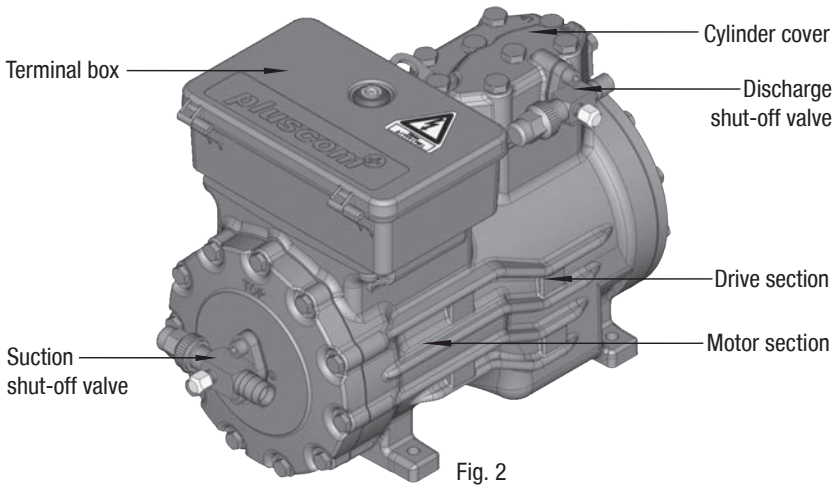
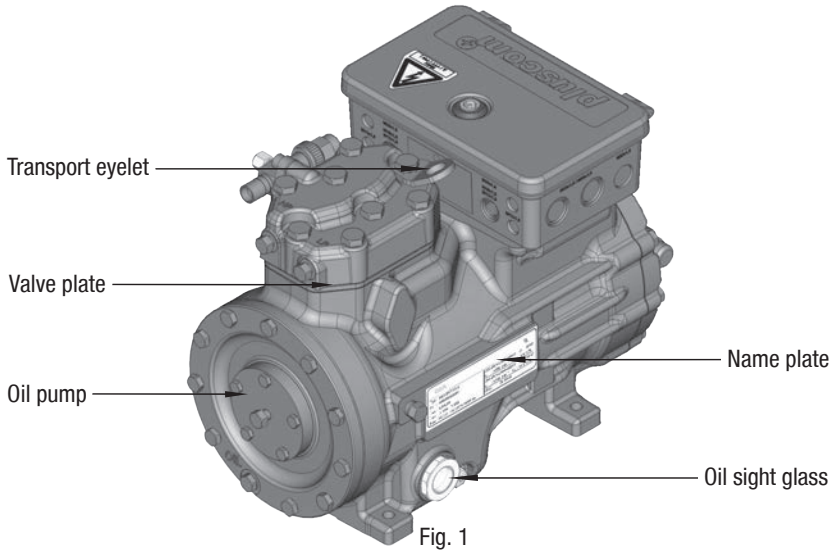

Dimension and connection values can be found in Chapter 9

## 2| Product description

### 2.2 Name plate (example)



 <b>GEA Bock GmbH</b> 72636 Frickenhausen, Germany			
1	Typ : HGX12P/110-4S	220-240VΔ/380-420VY -3- 50HZ	6
2	Nr. : AS35830A001	n : 1450 min <sup>-1</sup> V <sub>th.</sub> : 9,4 m <sup>3</sup> /h	7
3	I <sub>max.</sub> : 10,6/6,1A	265-290VΔ/440-480VY -3- 60HZ	8
4	I <sub>block.</sub> Δ: 45A Y: 26A	n : 1740 min <sup>-1</sup> V <sub>th.</sub> : 11,3 m <sup>3</sup> /h	9
5	p <sub>max.</sub> : ND(LP) / HD(HP)=19/28 bar	IP65 Öl: SE 55	10
			11
			12
			13

Fig. 3

1	Type designation	6	Voltage, circuit, frequency
2	Machine number	7	Nominal rotation speed } 50 Hz
3	maximum operating current	8	Displacement
4	Starting current (rotor blocked)	9	Voltage, circuit, frequency
5	ND (LP): max. admissible operating pressure (g) Low pressure side	10	Nominal rotation speed } 60 Hz
	HD (HP): max. admissible operating pressure (g) High pressure side	11	Displacement
		12	Oil type filled at the factory
		13	Terminal box protection type

**i** Observe the limits of application diagrams!

**i** Electrical accessories can change the IP protection class!

GB

### 2.3 Type key (example)

**HG X 12 P / 110-4 S**

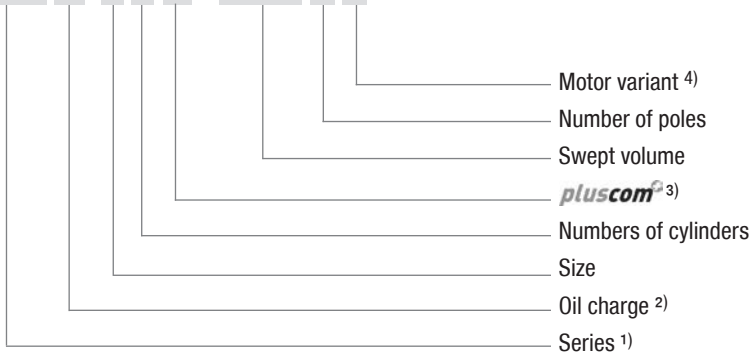

- 1) HG - Hermetic Gas-cooled (suction gas-cooled) for the normal- / air conditioning applications
- 2) X - Ester oil charge (HFC refrigerant, e.g. R134a, R404A/R507, R407C)
- 3) Additional declaration for Pluscom compressors
- 4) S - More powerful motor, e.g. for air-conditioning applications

# 3| Areas of application

## 3.1 Refrigerants

- HFKW / HFC: R134a, R404A/R507, R407C
- (H)FCKW / (H)CFC: R22

## 3.2 Oil charge

- The compressors are filled at the factory with the following oil type:
  - for R134a, R404A/R507, R407C FUCHS Reniso Triton SE 55
  - for R22 FUCHS Reniso SP 46

Compressors with ester oil charge (FUCHS Reniso Triton SE 55) are marked with an X in the type designation (e.g. HGX12P/110-4).



### INFO

For refilling, we recommend the above oil types.  
Alternatives: see lubricants table, Chapter 7.5



### ATTENTION

The oil level must be in the visible part of the sight glass; damage to the compressor is possible if overfilled or underfilled!

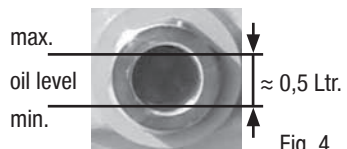

GB

## 3.3 Limits of application



### ATTENTION

Compressor operation is possible within the operating limits shown in the diagrams. Please note the significance of the shaded areas. Thresholds should not be selected as design or continuous operation points.

- Permissible ambient temperature (-20°C) - (+60°C).
- Max. permissible discharge end temperature 140°C.
- Max. permissible switching frequency 8x /h.
- A minimum running time of 3 min. steady-state condition (continuous operation) must be achieved.

For operation with supplementary cooling:

- Use only oils with high thermal stability.
- Avoid continuous operation near the threshold.

For operation with frequency converter:

- The maximum current and power consumption must not be exceeded. In the case of operation above the mains frequency, the application limit can therefore be limited.

When operating in the vacuum range, there is a danger of air entering on the suction side. This can cause chemical reactions, a pressure rise in the condenser and an elevated compressed-gas temperature. Prevent the ingress of air at all costs!



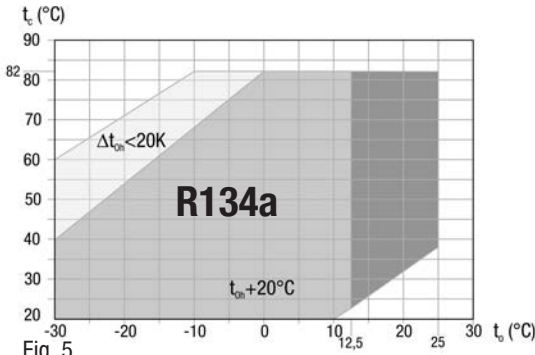

Fig. 5

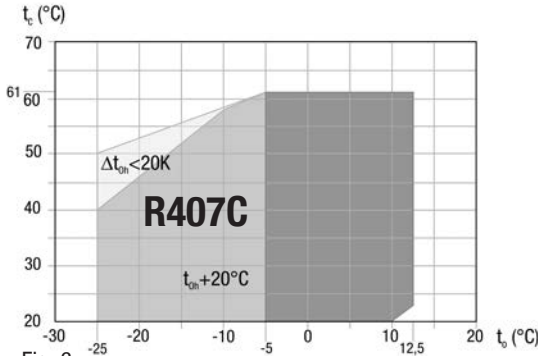

Fig. 6

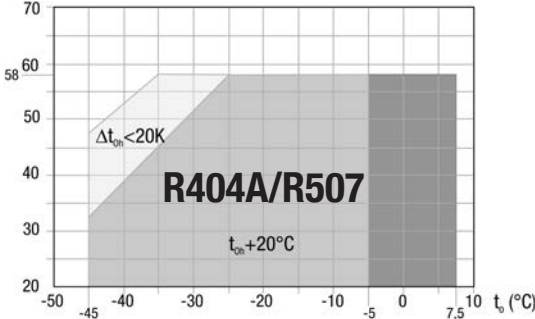

Fig. 7

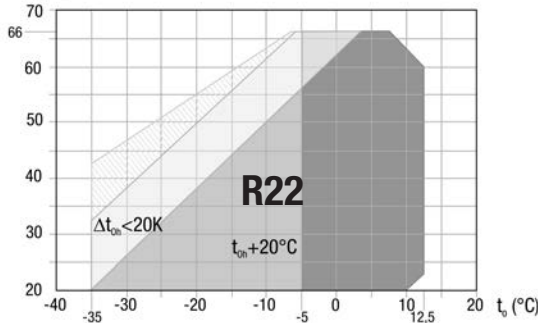

Fig. 8

- Unlimited application range
- Supplementary cooling or reduced suction gas temperature
- Supplementary cooling and reduced suction gas temperature
- Motor version S (more powerful motor)

$t_o$  Evaporation temperature (°C)

$t_c$  Condensing temperature (°C)

$\Delta t_{oh}$  Suction gas superheat (K)

$t_{oh}$  Suction gas temperature (°C)

**Max. permissible operating pressure (LP/HP)<sup>1)</sup>: 19/28 bar**

<sup>1)</sup> LP = Low pressure  
HP = High pressure

**Design for other areas on request**

# 4| Compressor assembly



## INFO

**New compressors are factory-filled with inert gas (3 bar nitrogen). Leave this service charge in the compressor for as long as possible and prevent the ingress of air. Check the compressor for transport damage before starting any work.**

### 4.1 Storage and transport



Fig. 9



Fig. 10

- Storage at (-30°C) - (+70°C), maximum permissible relative humidity 10% - 95%, no condensation
- Do not store in a corrosive, dusty, vaporous atmosphere or in a combustible environment.
- Use transport eyelet.
- Do not lift manually!
- Use lifting gear!

### 4.2 Setting up



## ATTENTION

**Attachments (e.g. pipe holders, additional units, fastening parts, etc.) directly to the compressor are not permissible!**

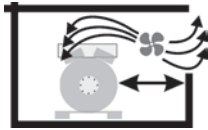

Fig. 11

- Provide adequate clearance for maintenance work.
- Ensure adequate compressor ventilation.



Fig. 12

- Do not use in a corrosive, dusty, damp atmosphere or a combustible environment.

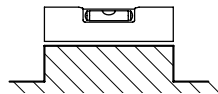

Fig. 13

- Setup on an even surface or frame with sufficient load-bearing capacity.
- Single compressor preferably on vibration damper.
- Duplex and parallel circuits always rigid.

### 4.3 Pipe connections



## ATTENTION

**Damage possible.**

**Do not solder as long as the compressor is under pressure. Superheating can damage the valve. Remove the pipe supports therefore from the valve for soldering and accordingly cool the valve body during and after soldering. Only solder using inert gas to inhibit oxidation products (scale).**

# 4| Compressor assembly

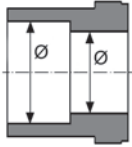

Fig. 14: graduated internal diameter

- The **pipe connections** have graduated inside diameters so that pipes with standart millimetre and inch dimensions can be used.
- The connection diameters of the shut-off valves are rated for maximum compressor output. **The actual required pipe cross section must be matched to the output. The same applies for non-return valves.**

## 4.4 Pipes

- Pipes and system components must be clean and dry inside and free of scale, swarf and layers of rust and phosphate. Only use air-tight parts.
- Lay pipes correctly. Suitable vibration compensators must be provided to prevent pipes being cracked and broken by severe vibrations.
- Ensure a proper oil return.
- Keep pressure losses to an absolute minimum.

## 4.5 Laying suction and pressure lines



**ATTENTION** Improperly installed pipes can cause cracks and tears, the result being a loss of refrigerant.



**INFO** Proper layout of the suction and discharge lines directly after the compressor is integral to the system's smooth running and vibration behaviour.

**A rule of thumb:** Always lay the first pipe section starting from the shut-off valve **downwards and parallel to the drive shaft**.

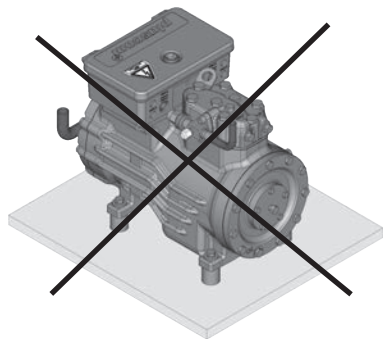
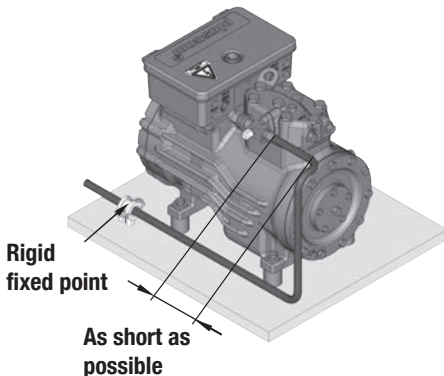

Fig. 15

# 4| Compressor assembly

## 4.6 Operating the shut-off valves

- Before opening or closing the shut-off valve, release the valve spindle seal by approx.  $\frac{1}{4}$  of a turn counter-clockwise.
- After activating the shut-off valve, re-tighten the adjustable valve spindle seal clockwise.

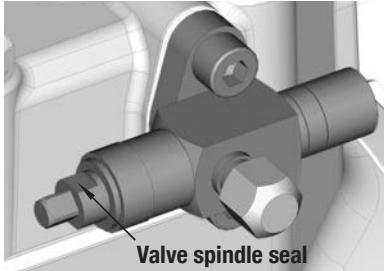

Fig. 16

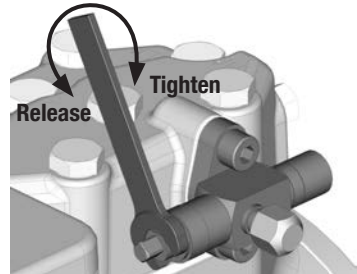

Fig. 17

## 4.7 Operating mode of the lockable service connections

GB

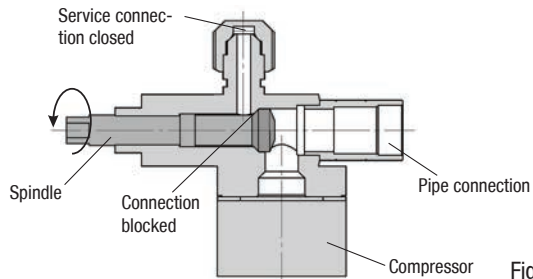

Fig. 18

### Opening the shut-off valve:

Spindle: turn to the left (counter-clockwise) as far as it will go.

—> Shut-off valve completely opened / service connection closed.

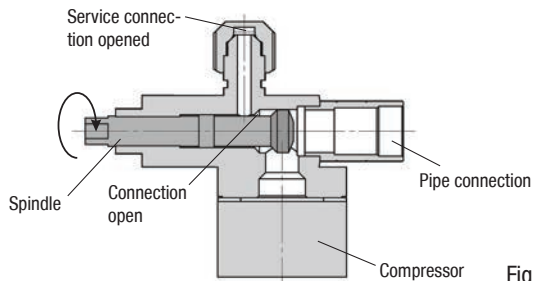

Fig. 19

### Opening the service connection

Spindle: Turn  $\frac{1}{2}$  - 1 turn to the right clockwise.

—> Service connection opened / shut-off valve opened.

09652-06.2015-DGbFEIRu

# 5| Electrical connection

## 5 Electrical connection



**DANGER**

**Risk of electric shock! High voltage!**  
**Only carry out work when the electrical system is disconnected from the power supply!**



**INFO**

Connect the compressor motor in accordance with the circuit diagram (see inside of terminal box).

- Use suitable cable entry point of the correct protection type (see name plate) for routing cables into the terminal box. Insert the strain reliefs and prevent chafe marks on the cables.
- Compare the voltage and frequency values with the data for the mains power supply.

**Only connect the motor if these values are the same.**

### 5.1 Information for contactor and motor contactor selection

All protection devices and switching or monitoring units must be fitted in accordance with the local safety regulations and established specifications (e.g. VDE) as well as with the manufacturer's information. **Motor protection switches are required!** Motor contactors, feed lines, fuses and motor protection switches must be rated on the basis of the maximum working current (see name plate). For motor protection use a current-dependent and time-delayed overload protection device for monitoring all three phases. Set the overload protection device so that it must be actuated within 2 hours, if there is 1.2 times the max. working current.

GB

### 5.2 Connection of the driving motor

The compressor is designed with a motor for star-delta circuits.

Designation on the name plate	Sticker on the terminal box
$\Delta / Y$	

Star-delta start-up is only possible on 230 V voltage supply. Example:

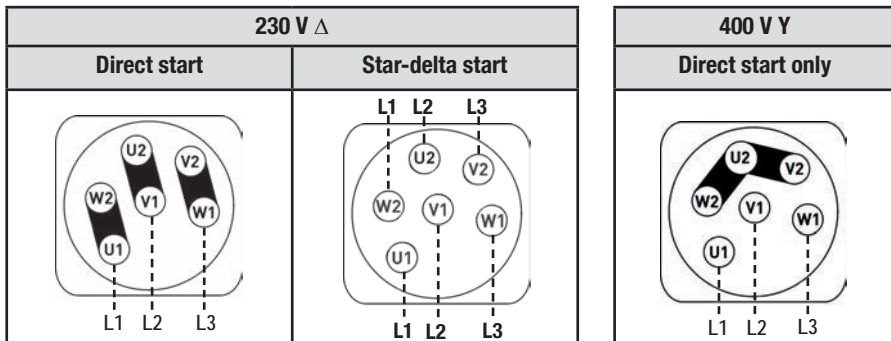

**INFO**

**The connection examples shown refer to the standard version. In the case of special voltages, the instructions affixed to the terminal box apply.**

5.3 Circuit diagramm for direct start 230 V Δ / 400 V Y --> compressor with MP10

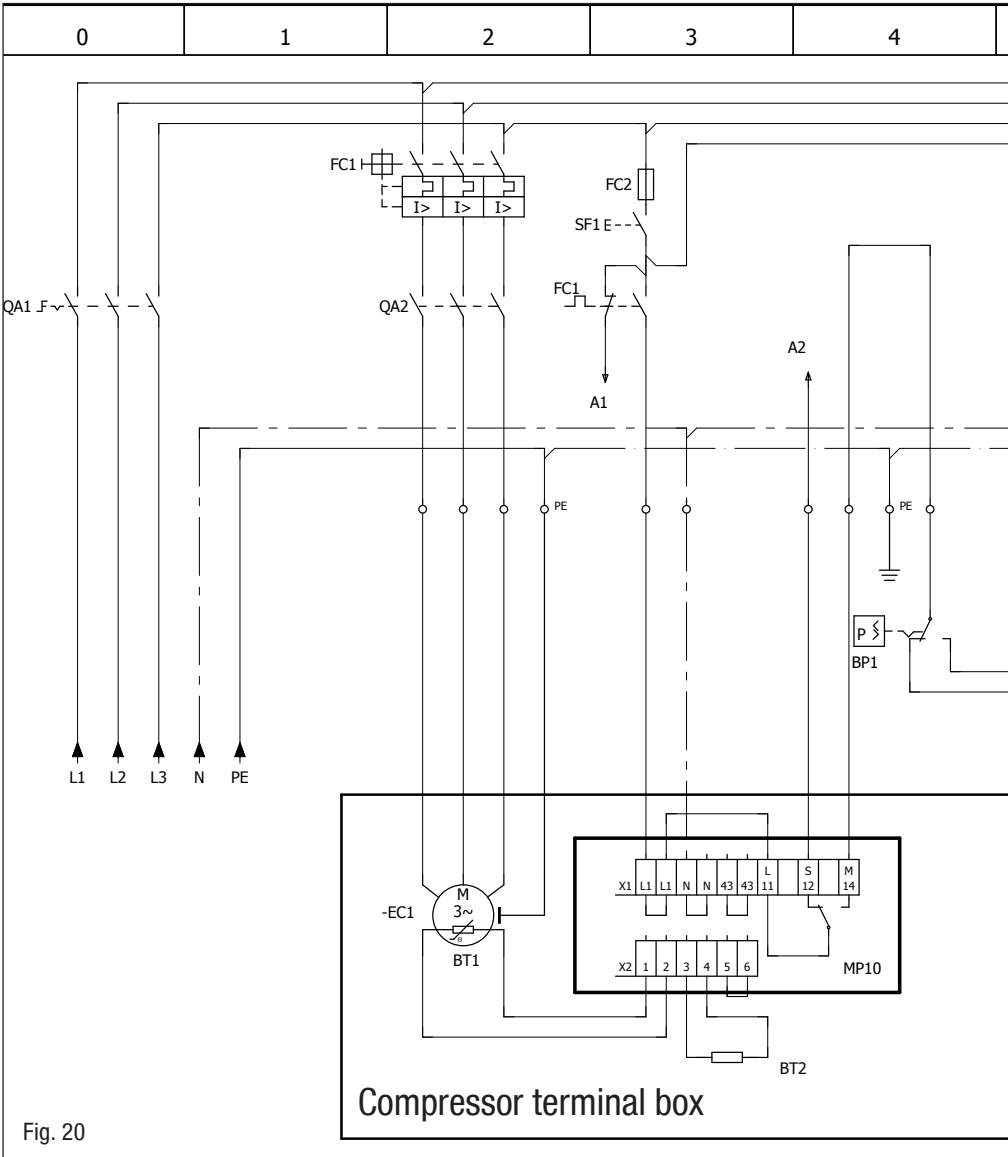
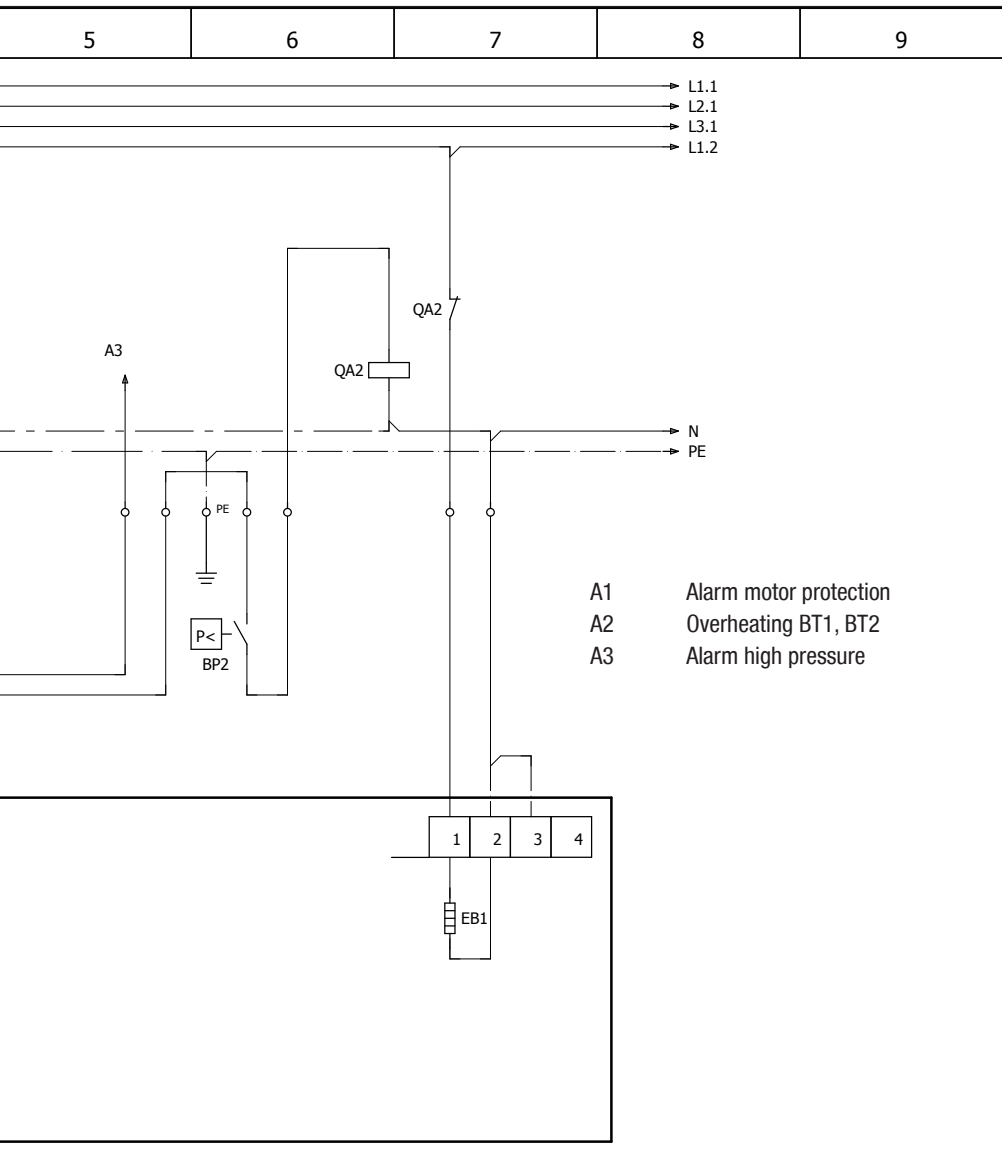

Fig. 20

BT1	Cold conductor (PTC sensor) motor winding
BT2	Thermal protection thermostat (PTC sensor)
FC1	Load circuit safety switches
FC2	Control power circuit fuse
BP1	Safety chain (high/low pressure monitoring)
BP2	Release switch (thermostat/pressostat)

GB



**GB**

QA1	Main switch
SF1	Control voltage switch
EC1	Compressor motor
QA2	Compressor contactor
MP10	Electronic trigger unit MP10
EB1	Oil sump heater

## 5| Electrical connection

### 5.4 Electronic trigger unit MP10

The compressor motor is fitted with cold conductor temperature sensors (PTC) connected to the electronic trigger unit MP10 in the terminal box. Readiness to operate is signalled by the H3 LED (green) after the power supply is applied. In the case of excess temperature in the motor winding, the unit switches off the compressor and the H1 LED lights red.

The hot gas side of the compressor can also be protected against overtemperature using a thermal protection thermostat (accessory). The H2 LED (red) is provided for the protection function.

**The unit trips when an overload or inadmissible operating conditions occur. Find and remedy the cause.**



INFO

The unit has a restart prevention device. After you have rectified the fault, interrupt the mains voltage. This unlocks the restart prevention device and the LEDs H1 and H2 go out.

### 5.5 Connection of the trigger unit MP10



INFO

Connect the trigger unit MP10 in accordance with the circuit diagram. Protect the trigger unit with a delayed-action fuse (FC2) of max. 4 A. In order to guarantee the protection function, install the trigger unit as the first element in the control power circuit.

Temperature monitoring connections:

- Motor winding: Terminals 1 - 2
- Thermal protection thermostat: Terminals 3 - 4
- Restart prevention: Terminals 5 - 6



#### ATTENTION

Terminals 1 - 6 on the trigger unit MP10 and terminals PTC 1 and PTC 2 on the compressor terminal board must not come into contact with mains voltage. This would destroy the trigger unit and PTC sensors. The supply voltage at L1-N (+/- for DC 24 V version) must be identical to the voltage at terminals 11, 12, 14 and 43.

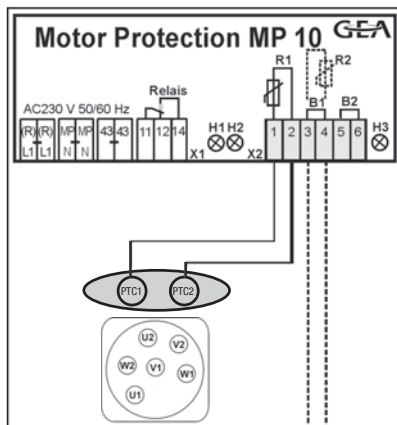

Fig. 21  
Terminal box



## 5| Electrical connection

### 5.6 Function test of the trigger unit MP10

Before start-up, troubleshooting or making changes to the control power circuit, check the functionality of the trigger unit:

Pos	Procedure	LED H1 red	LED H2 red	LED H3 green
1	<ul style="list-style-type: none"><li>• <b>Interrupt power supply (L1 or SF1)</b></li><li>• Release the motor temperature sensor connection (1 or 2)</li><li>• Release the hot gas temperature sensor (if installed) (3 or 4)</li></ul>	OFF	OFF	OFF
2	<ul style="list-style-type: none"><li>• <b>Restore the power supply (L1 or SF1)</b></li><li>• Function check of motor temperature sensor: operational</li><li>• Function check of hot gas temperature sensor: operational</li></ul>	ON	ON	ON
3	<ul style="list-style-type: none"><li>• <b>Interrupt power supply again (L1 or SF1)</b></li><li>• Reconnect terminals 1 or 2 and/or 3 or 4</li></ul>	OFF	OFF	OFF
4	<ul style="list-style-type: none"><li>• <b>Restore the power supply (L1 or SF1):</b></li><li>• MP10 is operational again</li></ul>	OFF	OFF	ON

The compressor and the trigger unit MP10 are operational when the H3 LED (green) lights.

GB

## 5.7 Circuit diagramm for direct start 230 V Δ / 400 V Y --> compressor with INT69 G

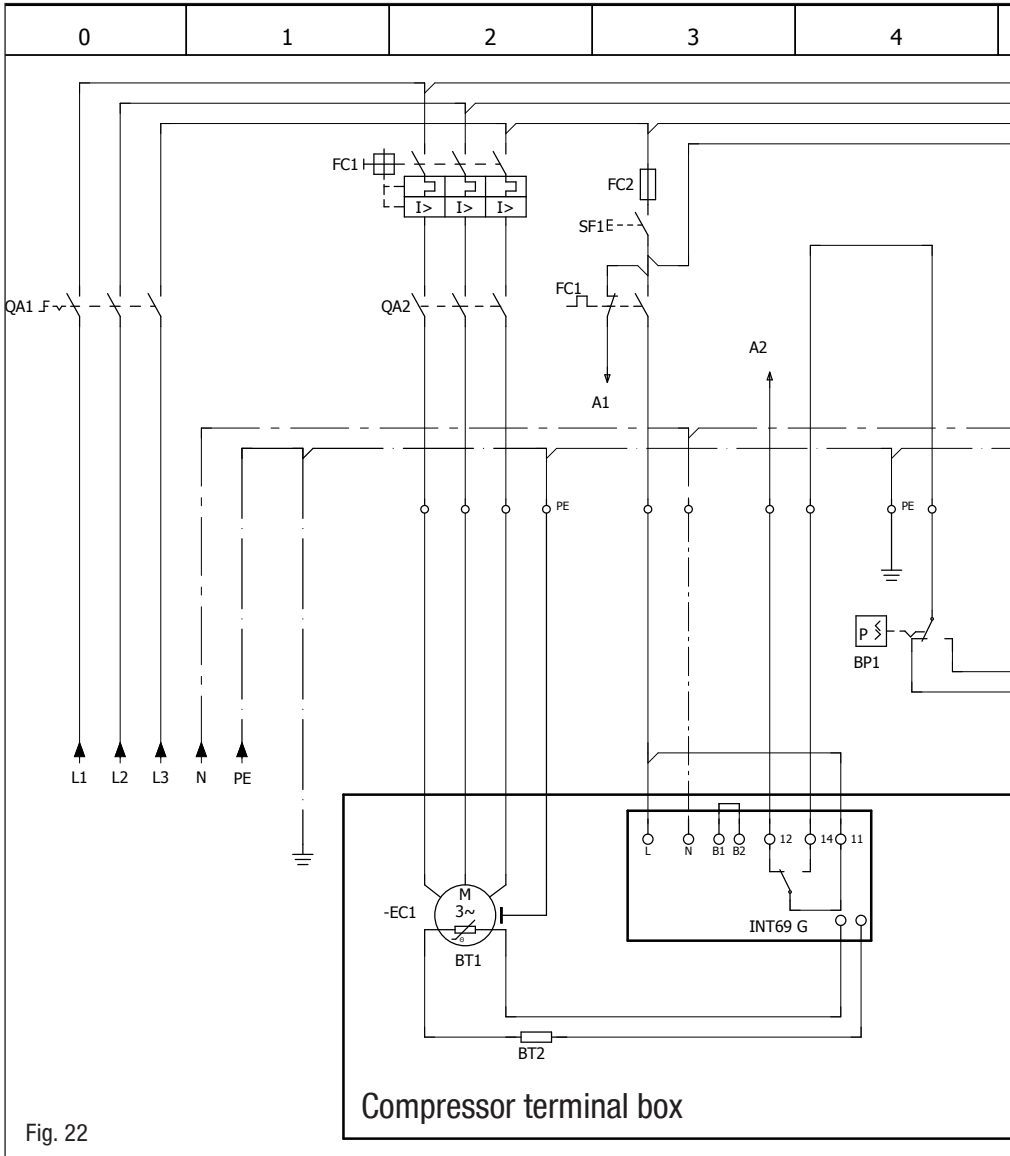
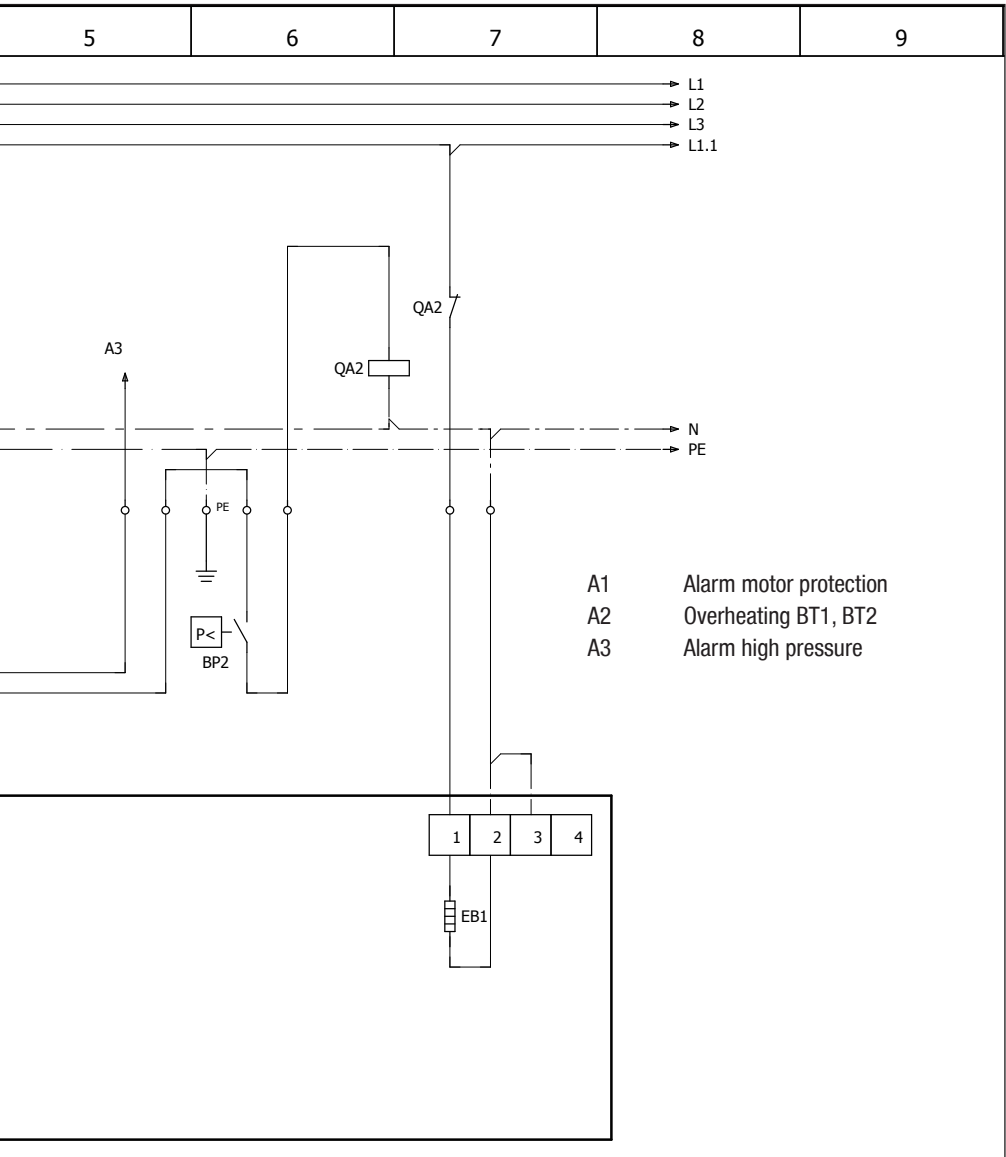

Fig. 22

BT1	Cold conductor (PTC sensor) motor winding
BT2	Thermal protection thermostat (PTC sensor)
FC1	Load circuit safety switches
FC2	Control power circuit fuse
BP1	Safety chain (high/low pressure monitoring)
BP2	Release switch (thermostat/pressostat)



**GB**

QA1	Main switch
SF1	Control voltage switch
EC1	Compressor motor
QA2	Compressor contactor
INT69 G	Electronic trigger unit INT69 G
EB1	Oil sump heater

## 5| Electrical connection

### 5.8 Electronic trigger unit INT69 G

The compressor motor is fitted with cold conductor temperature sensors (PTC) connected to the electronic trigger unit INT69 G in the terminal box. In case of excess temperature in the motor winding, the INT69 G deactivates the motor contactor. Once cooled, it can be restarted only if the electronic lock of the output relay (terminals B1+B2) is released by interrupting the supply voltage.

The hot gas side of the compressor can also be protected against overtemperature using thermal protection thermostats (accessory).

**The unit trips when an overload or inadmissible operating conditions occur. Find and remedy the cause.**



INFO

The relay switching output is executed as a floating changeover contact. This electrical circuit operates according to the quiescent current principle, i.e. the relay drops into a the idle position and deactivates the motor contactor even in case of a sensor break or open circuit.

### 5.9 Connection of the trigger unit INT69 G



INFO

Connect the trigger unit INT69 G in accordance with the circuit diagram. Protect the trigger unit with a delayed-action fuse (FC2) of max. 4 A. In order to guarantee the protection function, install the trigger unit as the first element in the control power circuit.



#### ATTENTION

Measure circuit BT1 and BT2 (PTC sensor) must not come into contact with external voltage.

This would destroy the trigger unit INT69 G and PTC sensors.

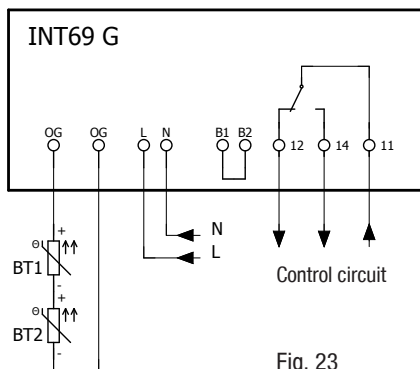

Fig. 23  
Terminal box

## 5| Electrical connection

### 5.10 Function test of the trigger unit INT69 G

Before commissioning, after troubleshooting or making changes to the control power circuit, check the functionality of the trigger unit. Perform this check using a continuity tester or gauge.

	Gauge state	Relay position
1.	Deactivated state	11-12
2.	INT69 G switch-on	11-14
3.	Remove PTC connector	11-12
4.	Insert PTC connector	11-12
5.	Reset after mains on	11-14

Relay position INT69 G

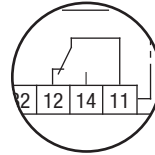

Fig. 24

# 6| Commissioning

## 6.1 Preparations for start-up



INFO

To protect the compressor against inadmissible operating conditions, high pressure and low pressure pressostats are mandatory on the installation side.

The compressor has undergone trials in the factory and all functions have been tested. There are therefore no special running-in instructions.

**Check the compressor for transport damage!**

## 6.2 Pressure strength test



DANGER

**Risk of bursting!**

**The compressor must only be pressurised using nitrogen (N<sub>2</sub>). Never pressurise with oxygen or other gases!**

**The maximum permissible overpressure of the compressor must not be exceeded at any time during the testing process (see name plate data)! Do not mix any refrigerant with the nitrogen as this could cause the ignition limit to shift into the critical range.**

The compressor has been factory-tested for pressure resistance. The following must be observed if the entire plant is subjected to an additional pressure strength test:

- Test the refrigeration circuit according to EN 378-2 or a corresponding safety standard.

## 6.3 Leak test



DANGER

**Risk of bursting!**

**Do not mix any refrigerant with the nitrogen (N<sub>2</sub>) as this could cause the ignition limit to shift into the critical range.**

- Carry out the leak test of the refrigerating system in accordance with EN 378-2 or a corresponding safety standard **without including the compressor.**

## 6.4 Evacuation



ATTENTION

**Do not start the compressor if it is under vacuum. Do not apply any voltage - even for test purposes (must only be operated with refrigerant).**

Under vacuum, the spark-over and creepage current distances of the terminal board connection bolts shorten; this can result in winding and terminal board damage.

- First evacuate the **system** and then include **the compressor in the evacuation process.**
- Relieve the compressor pressure.
- Open the suction and pressure line shut-off valves.
- Evacuate the suction and discharge pressure sides using the vacuum pump.
- At the end of the evacuation process, the vacuum should be < 1.5 mbar when the pump is switched off.
- Repeat this process as often as is required.

# 6| Commissioning

## 6.5 Refrigerant charge



### CAUTION

**Wear personal protective clothing such as goggles and protective gloves!**

- Make sure that the suction and pressure line shut-off valves are open.
- With the compressor switched off, add the liquid refrigerant directly to the condenser or receiver, breaking the vacuum.
- If the refrigerant needs topping up after starting the compressor, it can be topped up in vapour form on the suction side, or, taking suitable precautions, also in liquid form at the inlet to the evaporator.



### ATTENTION

- **Avoid overfilling the system with refrigerant!**
- **To avoid shifts in concentration, zeotropic refrigerant blends (e.g. R407C) must always only be filled into the refrigerating plant in liquid form.**
- **Do not pour liquid coolant through the suction line valve on the compressor.**
- **It is not permissible to mix additives with the oil and refrigerant.**

## 6.6 Start-up



### WARNING

**Ensure that both shut-off valves are open before starting the compressor!**

- Check that the safety and protection devices (pressure switch, motor protection, electrical contact protection measures, etc.) are all functioning properly.
- Switch on the compressor and allow to run for a minimum of 10 min.
- **Check the oil level by:** The oil must be visible in the sightglass.



### ATTENTION

**If larger quantities of oil have to be topped up, there is a risk of oil hammer effects.  
If this is the case check the oil return!**

## 6.7 Avoiding slugging



### ATTENTION

**Slugging can damage the compressor and cause refrigerant to leak.**

### To prevent slugging:

- The complete refrigeration system must be properly designed.
- All components must be compatibly rated with each other with regard to output (particularly the evaporator and expansion valves).
- Suction gas superheat at the compressor input **should be min. 7 - 10 K**. (check the setting of the expansion valve).
- The system must reach a state of equilibrium.
- Particularly in critical systems (e.g. several evaporator points), measures are recommended such as replacement of liquid traps, solenoid valve in the liquid line, etc.

**There should be no movement of coolant whatsoever while the compressor is at a standstill.**

# 6| Commissioning

## 6.8 Connection of oil level regulator

The connection "O" is provided for installing an oil level regulator. A corresponding adapter must be obtained from the trade.

# 7| Maintenance

## 7.1 Preparation



### WARNING

**Before starting any work on the compressor:**

- Switch off the compressor and secure it to prevent a restart.
- Relieve compressor of system pressure.
- Prevent air from infiltrating the system!

**After maintenance has been performed:**

- Connect safety switch.
- Evacuate compressor.
- Release switch lock.

GB

## 7.2 Work to be carried out

In order to guarantee optimum operational reliability and service life of the compressor, **we recommend** carrying out servicing and inspection work at regular intervals:

- **Oil change:**
  - not mandatory for factory-produced series systems.
  - for field installations or when operating near the application limit: for the first time after 100 to 200 operating hours, then approx. every 3 years or 10,000 - 12,000 operating hours. Dispose of used oil according to the regulations; observe national regulations.
- **Annual checks:** Oil level, leak tightness, running noises, pressures, temperatures, function of auxiliary devices such as oil sump heater, pressure switch.

## 7.3 Spare parts recommendation

HG12P / ...	60-4 S	75-4 (S)	90-4 (S)	110-4 (S)
Designation	Ref. No.	Ref. No.	Ref. No.	Ref. No.
Set of gaskets	80339			
Valve plate kit	80352		80353	
Oil pump kit	08324			

**Only use genuine GEA Bock spare parts!**

09652-06.2015-DGbFEIRu



# 7 | Maintenance

## 7.4 Accessories

Available accessories can be found on the Internet at [www.gea.com](http://www.gea.com)

## 7.5 Extract from the lubricants table

The oil type filled as standard in the factory is marked on the **name plate**. **This oil type should be used as a preference.** Alternatives are stated in the extract from our lubricants table below.

Refrigerants	GEA Bock standard oil types	Recommended alternatives
<b>HFC</b> (e.g. R134a, R407C, R404A)	<b>Fuchs Reniso Triton SE 55</b>	Fuchs Reniso Triton SEZ 32 Esso/Mobil EAL Arctic 46 Sunoco Suniso SL 46 Texaco Capella HFC 55
<b>HCFC</b> (e.g. R22)	<b>Fuchs Reniso SP 46</b>	Fuchs Reniso SP 32 BP Energol LPT 46 Sunoco Suniso 3,5 GS Texaco Capella WF 46

GB

## 7.6 Decommissioning

Close the shut-off valves on the compressor. Drain the refrigerant (it must not be discharged into the environment) and dispose of it according to the regulations. When the compressor is depressurised, undo the fastening screws of the shut-off valves. Remove the compressor using an appropriate hoist. Dispose of the oil inside in accordance with the applicable national regulations.

## 8 | Technical data

Type	No. of cylinders	Displacement 50 / 60 Hz (1450 / 1740 rpm)	Electrical data ③			Weight	Connections ④		Oil charge	Sound pressure level
			Voltage ①	Max. Operating current ② Δ / Y	Max. power consumption ②		Starting current (rotor locked) Δ / Y	Discharge line DV		
HG12P/60-4 S		m <sup>3</sup> /h		A	kW	A	mm (inch)	Litr.	dB(A)	
		5,4 / 6,4	6,8 / 3,9	2,2	40 / 23	48			58,5 / 58 / 57	
HG12P/75-4		6,7 / 8,1	7,1 / 4,1	2,3	40 / 23	48			59 / 58,5 / 58	
HG12P/75-4 S		6,7 / 8,1	8,0 / 4,6	2,6	43 / 25	49			59 / 58,5 / 58	
HG12P/90-4	2	8,0 / 9,6	8,5 / 4,9	2,8	43 / 25	49	12 (1/2)	0,8	59,5 / 59 / 58	
HG12P/90-4 S		8,0 / 9,6	8,8 / 5,1	2,9	45 / 26	49			59,5 / 59 / 58	
HG12P/110-4		9,4 / 11,3	9,2 / 5,3	3,1	43 / 25	49			60 / 59 / 58	
HG12P/110-4 S		9,4 / 11,3	10,6 / 6,1	3,6	45 / 26	49			60 / 59 / 58	

① Tolerance (± 10%) relative to the mean value of the voltage range.  
Other voltages and types of current on request.

② - The specifications for max. power consumption apply for 50Hz operation.  
For 60Hz operation, the specifications have to be multiplied by the factor 1.2. The max. working current remains unchanged.

- Take account of the max. operating current / max. power consumption for design of fuses, supply lines and safety devices. Fuse: Consumption category AC3

③ All specifications are based on the average of the voltage range

④ For solder connections

⑤ **L** = low temperature (-35 / 40 °C), **M** = normal cooling (-10 / 45 °C),  
**H** = air conditioning (5 / 50 °C) sound pressure level measured in low reflection measuring area, measuring distance 1m.

Compressor operation at 50 Hz (1450 rpm), refrigerant R404A.  
Values stated are average values, tolerance ± 2 dB(A).

## 9| Dimensions and connections

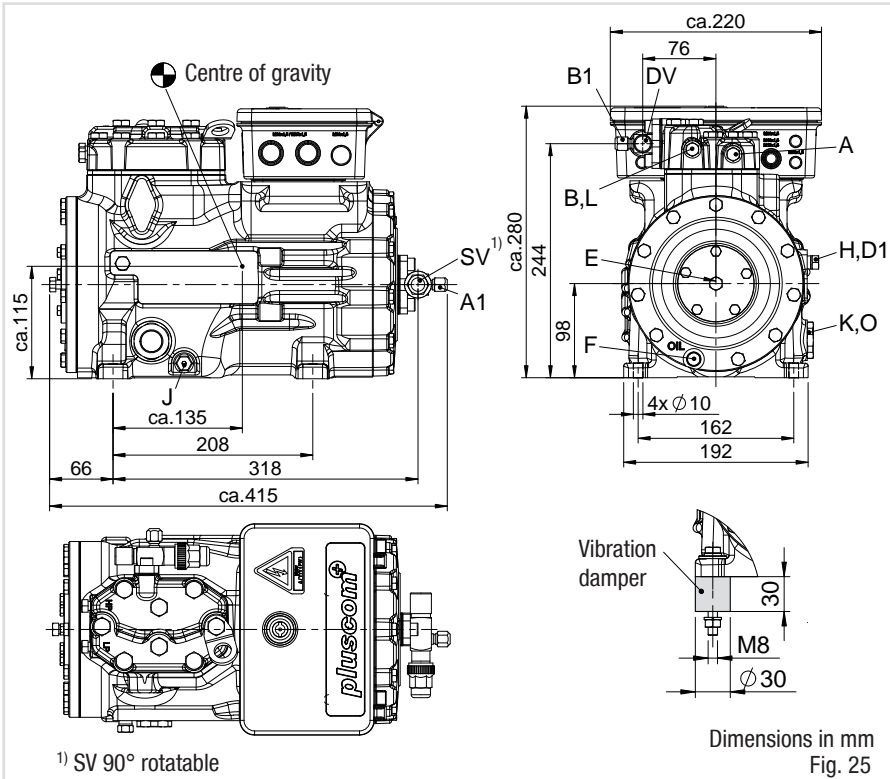

1) SV 90° rotatable

GB

SV	Suction line	see technical data, Chapter 8	
DV	Discharge line		
A	Connection suction side, not lockable		1/8" NPTF
A1	Connection suction side, lockable		7/16" UNF
B	Connection discharge side, not lockable		1/8" NPTF
B1	Connection discharge side, lockable		7/16" UNF
D1	Connection oil return from oil separator		1/4" NPTF
E	Connection oil pressure gauge		1/8" NPTF
F	Oil drain		M8
H	Oil charge plug		1/4" NPTF
J	Connection oil sump heater		Ø 15 mm
K	Sight glass		1 1/8" - 18 UNEF
L	Connection thermal protection thermostat		1/8" NPTF
O	Connection oil level regulator		1 1/8" - 18 UNEF

# 10| Declaration of conformity and installation

## DECLARATION OF CONFORMITY CE 04

for using the compressors within the European Union  
(in accordance with Low Voltage Directive 2006/95/EC)

We hereby declare that the following refrigerating compressors

Product designation: **HG12P**

comply with the Low Voltage Directive 2006/95/EC.

Applied harmonised standard:

EN 60034-1:2010

EN 60204-1:2006

## DECLARATION OF INSTALLATION

for using the compressors within the European Union  
(in accordance with Machinery Directive 2006/42/EC)

The manufacturer: GEA Bock GmbH, Benzstraße 7  
72636 Frickenhausen, Tel.: 07022/9454-0

hereby declares that the refrigerating compressor **HG12P** complies with the basic requirements of Appendix II 1B of the Machinery Directive 2006/42/EC.

Applied harmonised standard:

EN 12693:2008 and the corresponding standards referenced

A partly completed machine may only be put into operation when it has been established that the machine, into which the partly completed machine is to be installed, conforms to the regulations of the Machinery Directive (2006/42/EC).

The manufacturer undertakes to transmit electronically the special documentation required by individual states for partly completed machinery on request.

The special technical documentation required for partly completed machinery has been created in accordance with Appendix VII Part B.

Person responsible for documentation is: Wolfgang Sandkötter, Benzstraße 7, 72636 Frickenhausen.

Frickenhausen, 01.11.2011



ppa. Wolfgang Sandkötter,  
Chief Development Officer

# 11| Service

Dear customer,

GEA Bock compressors are top-quality, reliable and service-friendly quality products. If you have any questions about installation, operation and accessories, please contact our technical service or specialist wholesaler and/or our representative. The GEA Bock service team can be contacted by phone with a **toll-free hotline 00 800 / 800 000 88** or via **e-mail: [refrigeration@gea.com](mailto:refrigeration@gea.com)**

Yours faithfully

**GEA Bock GmbH**  
**Benzstraße 7**  
**72636 Frickenhausen**  
**Germany**

**GB**



*We live our values.*

Excellence • Passion • Integrity • Responsibility • GEA-versity

GEA Group is a global engineering company with multi-billion euro sales and operations in more than 50 countries. Founded in 1881, the company is one of the largest providers of innovative equipment and process technology. GEA Group is listed in the STOXX® Europe 600 index.

## **GEA Bock GmbH**

Benzstraße 7, 72636 Frickenhausen, Germany  
Telephone: +49 7022 9454-0, Fax: +49 7022 9454-137  
refrigeration@gea.com, [www.gea.com](http://www.gea.com)