

HG34P | HG34e

Maintenance manual

About these instructions

Read these instructions before assembly and before using the compressor. This will avoid misunderstandings and prevent damage. Improper assembly and use of the compressor can result in serious or fatal injury.

Observe the safety instructions contained in these instructions.

Contact

GEA Bock GmbH
Benzstraße 7
72636 Frickenhausen
Germany

Telephone +49 7022 9454 0
Fax +49 7022 9454 137
refrigeration@gea.com
www.gea.com

Liability and warranty

Manufacturer's liability and warranty are excluded if

- Alterations and functional modifications have been carried out
- No original replacement parts have been used

Contents

	Page
1 Safety	3
2 Fault diagnosis	4
3 Disassembly of the compressor	8
4 Checking the compressor parts	19
5 Assembly of compressor	21
6 Exploded drawing	33







1 | Safety

Safety instructions



Target group of these instructions

- Work on the compressor may only be carried out by persons whose technical training, skills and experience along with their knowledge of pertinent regulations and documentation means that they are capable of assessing the work to be carried out and detecting any possible dangers
- Specialist can mean a refrigeration technician for example. Note that electrical work may only be carried out by a qualified electrician. Alternatively, on a country-specific basis, persons who have undergone electrotechnical instruction and who have proof of their qualification are also permitted to carry out the work.

Identification of safety instructions

	DANGER!	Indicates a dangerous situation which, if not avoided, will cause immediate fatal or serious injury.
	DANGER!	Indicates a dangerous situation which by electrical current, if not avoided, will cause immediate fatal or serious injury.
	WARNING!	Indicates a dangerous situation which, if not avoided, may cause fatal or serious injury.
	CAUTION!	Indicates a dangerous situation which, if not avoided, may cause fairly severe or minor injury.
	ATTENTION!	Indicates a situation which, if not avoided, may cause property damage.
	INFO!	Important information / tips on simplifying work.

General safety instructions

	DANGER!	<p>Risk of electric shock</p> <ul style="list-style-type: none"> • Before you carry out any repair work, disconnect the compressor from the electricity network. • Turn the main switch to "0" (OFF). • Secure the main switch against an unauthorised restart.
	WARNING!	<ul style="list-style-type: none"> • Refrigerating compressors are pressurised machines and therefore require particular caution and care in handling. • Risk of burns! Depending on the operating conditions, surface temperatures of over 60 °C on the pressure side or below 0 °C on the suction side can be reached. • The maximum permissible overpressure must not be exceeded, even for testing purposes.

2 | Fault diagnosis

Fault diagnosis

In case of malfunctions during compressor operation we recommend to prepare a measurement record for aiding the fault search:

- Pressure measurement: Discharge side, suction side, oil pressure
- Temperature measurement: Compressor casing, discharge end temperature, suction gas overheating

According to the expected cause of the fault it may be necessary to check the electrical systems for faults in the control.

In order to localize the causes of operating malfunctions as easy as possible we have compiled the following table with suggestion for remedying compressor malfunctions. Further information is available on our failure analysis slide that can be downloaded on www.gea.com.

Function faults - Symptoms

Function faults arising most frequently and their symptoms are:

- Compressor stoppage, compressor cutoff
 - Compressor does not start
 - Compressor starts and then stops again
- Refrigerant performance too low
- Too high compressor temperature
- Oil problems
- Abnormal compressor running noise

Compressor stand still

Compressor does not start

Problem	Possible cause	Remedy
Control circuit is interrupted	Main- or control fuse is switched off or tripped <ul style="list-style-type: none"> - Setting / selection incorrect - Motor overloaded - Undervoltage - Starter contacts / shorted contacts / earthed contacts 	Replace fuse Determine and remove the cause
	Cut off through: <ul style="list-style-type: none"> - Low pressure switch - High pressure switch - Heat protection thermostat - Control thermostat - Other safety elements 	Locate the interruption in the circuit and remove
Main- or control circuit is switched off		switch on
Main- or control circuit is wired incorrectly		wire correctly
Bridges / connection cable in terminal box is wired incorrectly		wire correctly
Incorrect voltage		connect to correct voltage
Phase or neutral is missing		connect
Overload / motor safety is switched off	Setting / selection incorrect	Check design
	Function / drive not working	Check cable, electronic system
	Motor overloaded	Check operating conditions
	Undervoltage	Determine and remove the cause
	Short circuit ON / OFF	Check control
	Starter contacts / shorted contacts / earthed contacts	Check motor for winding damages / check shorted contacts

2 | Fault diagnosis

Problem	Possible cause	Remedy
Overload / Motor safety switch is tripped	Two phase run	Ensure three phase run
	Very unequal phase runs	Determine and remove the cause

Compressor cutoff

Compressor starts and stops again

Problem	Possible cause	Remedy
Cutoff through lowpressure switch	Suction pressure too low: - Check the setting of the low pressure switch	- Adjust the switching points or replace switch
	- Suction valve of the compressor closed	- Open suction valve
	- Capacity of compressor too large	- Check operating conditions
	- Refrigerant deficiency	- Leak test / add refrigerant
	- Filter / dryer in the liquid line blocked	- Replace filter / dryer
	- Expansion valve not functioning properly	- Check the setting of the expansion valve
	- Solenoid valve on the liquid line not opening	- Check the control / function
Cutoff through highpressure switch	Condensing pressure too high: - Check the setting of the high-pressure switch	- Adjust the switching points or replace switch
	- Pressure valve of the compressor closed	- Open the pressure valve
	- Condenser fan not functioning	- Check the control / replace motor
	- Condenser fan is dirty	- Cleaning of condenser
	- Excessive refrigerant filling	- Extract refrigerant to normal filling
	- Non-condensable gases in refrigerant	- Extract refrigerant and evacuate the refrigeration plant / refill refrigerant
Cutoff through heatprotection thermostat (accessory)	Discharge end temperatures is too high - Operating limits of compressor exceeded	- Adapt the operating conditions to the operating range
	- Suction gas overheating	- Check expansion valve / check insulation on the suction side
	- Refrigerant of the condenser insufficient	- Check fan motors / Clean the condenser
	- Valve plate damage	- Replace valve plate
	- Internal safety valve has opened	- Replace safety valve -> Check compressor and refrigeration plant Determine and remove the cause for the inadmissible high pressure in the high-pressure side
Cutoff through control thermostat	Temperature over / below the desired range	Check operating points
Cooling control or other switch / control devices are switched off	Setting / selection incorrect	- Check control design - Change control
	Function / drive incorrect	- Check drive / function - Check cables, contacts etc.

2 | Fault diagnosis

Problem	Possible cause	Remedy
MP10 switched off	Function / drive not working	Check function / drive
	Motor overloaded	Check operating conditions
	Undervoltage	Determine and remove the cause
	Short circuit ON / OFF	check control
	Starter contacts / shorted contacts / earthed contacts	Check motor for winding damage / check shorted contacts
	Two-phase run	Ensure three phase run
	Very unequal phase runs	Determine and remove the cause

Refrigerant performance too low

Problem	Possible cause	Remedy
Suction pressure too high	- Evaporator iced up	- Remove the cause
	- Expansion valve not functioning properly	- Check expansion valve setting; replace valve, if necessary
	- Lack of compressor capacity	- Check the function of the compressor by evacuating to vacuum. Check function of capacity regulator (accessory)
	- Shortage of refrigerant	- Run leakage test / refill refrigerant
Suction pressure too low	- See „Cutoff through low-pressure switch“	- Checking
High-pressure too high	- See „Cutoff through high-pressure switch“	- Checking
High-pressure too low	- Condenser being cooled to much	- Adjust the control of condenser cooling
	- Lack of compressor capacity	- Check compressor / Check the functioning of capacity regulator
	- Pressure laminations of valve plate leaking	- Replace valve plate
	- By-pass between suction and discharge side	- Localize leak between the discharge and suction side and repair it

Refrigerant temperature too high

Problem	Possible cause	Remedy
Suction gas temperature too high	- Suction gas overheating	- Adjust expansion valve Insulate the gas suction line
	- Too little refrigerant filling	- Establish the operating filling (see Operating Instruction for the refrigeration plant) Localize leak
	- Liquid filter blocked	- Clean / replace filter / dryer
	- Shortage of refrigerant	- Run leakage test / refill refrigerant
Discharge pipe temperature too high	- Suction gas temperature too high (Condensing pressure too high)	- Adjust expansion valve Insulate the gas suction line - see „Cutoff through high-pressure switch“
	- Operating limits of compressor exceeded	- see „Cutoff through heat-protection thermostat“

2 I Fault diagnosis

Problem	Possible cause	Remedy
Discharge pipe temperature too high	- Cooling insufficient	- Check refrigerant filling - Adjust expansion valve
	- Short circuit between the discharge and the suction side of the compressor	- Check gaskets on valve plate / change
	- Valve plate damage	- Replace valve plate

Oil problems

Problem	Possible cause	Remedy
Oil pressure too low	- Refrigerant in oil	- see „Oil foams“
	- Too little oil in compressor	- Add oil and search for the cause of oil loss
	- Oil filter dirty / blocked	- Clean / replace oil filter Change oil
Oil foams during start-up phase	- Liquid refrigerant has moved into the oil sump	- Check the laying of pipes - Installation of the check valve in the discharge line - Installation of the solenoid valve in the liquid line - Check the control
Oil foams during operating	- Expansion valve not functioning	- Adjust / replace expansion valve
Oil level decreases	- During start-up, a portion of the oil is carried to the refrigeration plant with the refrigerant	- Refrigerant and oil get mixed. After some time the oil level should stabilize. Add oil, if necessary.
	- Refrigerant in oil	- see „Oil foams during start-up phase“
	- Piston rings worn	- Replace piston rings
	- Suction / discharge laminations of the valve plate leaking	- Replace valve plate

Abnormal running noise from compressor

Problem	Possible cause	Remedy
Fixation of compressor is loose	- Screwed connections have become loose - Securing elements for screwed connections missing	- Tighten the screwed connections and secure them anew
	- Vibration metals defective	- Replace vibrations metals
Liquid shock	- Liquid refrigerant reaching the compressor	- Adjust / check expansion valve Check refrigerant filling Check evaporator fan - Icing-up of the evaporator
	- Oil shocks because of too much oil	- Check oil level Check the dimensioning of pipes (gas velocity) Replace worn piston rings
Capacity regulator (accessory)	- Switching on and off constantly / oscillating	- Check the control
	- Defective	- Replace capacity regulator valve

3 | Disassembly of the compressor

Disassembly and assembly of the compressor



WARNING! Before starting any work on the compressor:

- Switch of the compressor and guard it against switching on.
- Relieve the compressor from system pressure
- Prevent air from infiltrating the system
- Move and transport the compressor using an appropriate hoist

After the work is finished:

- Connect the safety switch and check its function
- Evacuate the compressor
- Before commissioning, check whether all the components installed by the user have been mounted expertly and are connected pressure-tight to the compressor
- Open the pressure and suction shut-off valves
- Set off the switching-on lock

Important Notes



INFO!

- Use only new gaskets for assembly.
- For 2 pole compressors the stator is built at factory in while it is still warm. A removal is therefore not possible.
- For 4 pole compressors, the stator screw (Pos. 1020 in the parts list) has to be replaced. Because of the coating, tighten stator screw once only. Note hardening time!
- The following illustrations show a HG34 compressor in standard design. Components of other designs (z.B. aluminium design) can differ from these illustrations. However, the procedure for disassembly and assembly of the compressor is identical.

3 | Disassembly of the compressor

Removal of the compressor from the refrigerant system

Removal of the compressor from the system, shut-off valves remaining on the compressor

- Extract the refrigerant from the system into a container which may be used for this refrigerant
- Evacuate the systems including the compressor
- Cut off the vacuum, humid air should not get into the system
- Close the shut-off valves on the suction and discharge side; remove the compressor
- Close the suction and discharge line connection points on the system with stoppers
- Relieve the pressure before dismounting the compressor

Removal of the compressor from the system, shut-off valves for compressor remaining at the system

- Close shut-off valves on the suction and discharge side
- Extract the refrigerant from the compressor into a container which may be used for this refrigerant
- Evacuate the compressor
- Cut off the vacuum
- Remove the compressor from the system
- Close the suction and discharge shut-off ports on the compressor with stoppers

Disassembly of compressor

The disassembly of the compressor is explained in separate steps on the following pages. The indicated parts list positions refer to the spare parts lists, repair set lists, special accessories part lists and are available online at www.gea.com.

You can find the exploded drawing at the end of the maintenance manual.

Preparation: Necessary tools

Pos.	Tool	Size
1	Oil collection container	> 1,5 ltr.
2	Spanner	SW 10, 13, 14, 17, 19
3	Allen key	6 mm, 10 mm
4	Needle-nosed pliers	
5	Magnet	

3 | Disassembly of the compressor

1 Draining the oil

Position in parts list

Parts list position: 480

Tools: Spanner SW 17, Oil collection container > 1,5 liter

Working course

- The compressor has to be depressurized
- Place the container in a way that the oil can flow into it
- Loosen oil drain screw and unscrew
- Drain off oil

480, 482

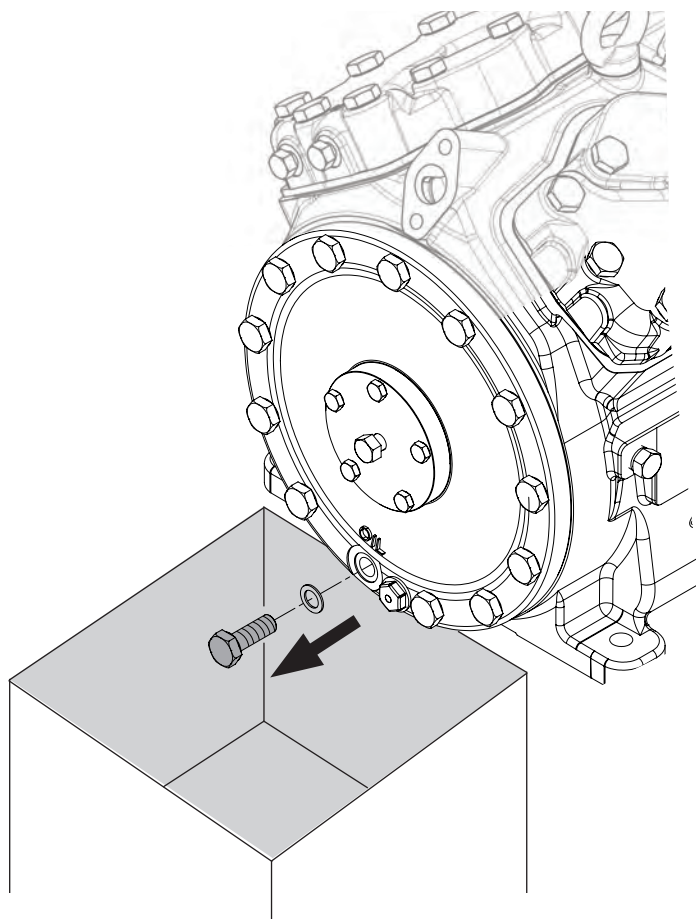

3 | Disassembly of the compressor

2 | Disconnecting the electrical connections

Position in parts list

Parts list position: 2150, 1055, 1065, 1071

Tools: Spanner SW 13

Working course

- Remove terminal board and PTC terminal board

1055,
1065,
1071, 2150

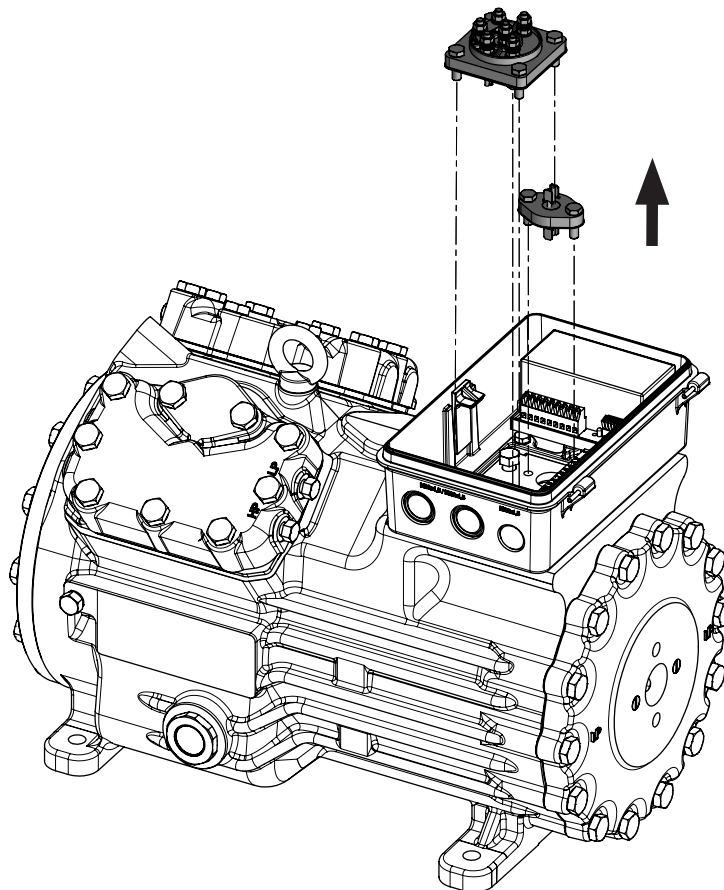

3 | Disassembly of the compressor

3 Remove housing cover suction side

Position in parts list

Parts list position: 720, 721, 740

Tools: Spanner SW 17

Working course

- To collect leaking oil, protect the assembly area with absorbent material.
Dispose of the material environmentally sound afterwards

740

- Loosen the screw at the housing cover and unscrew

720, 721

- Take off housing cover and seal

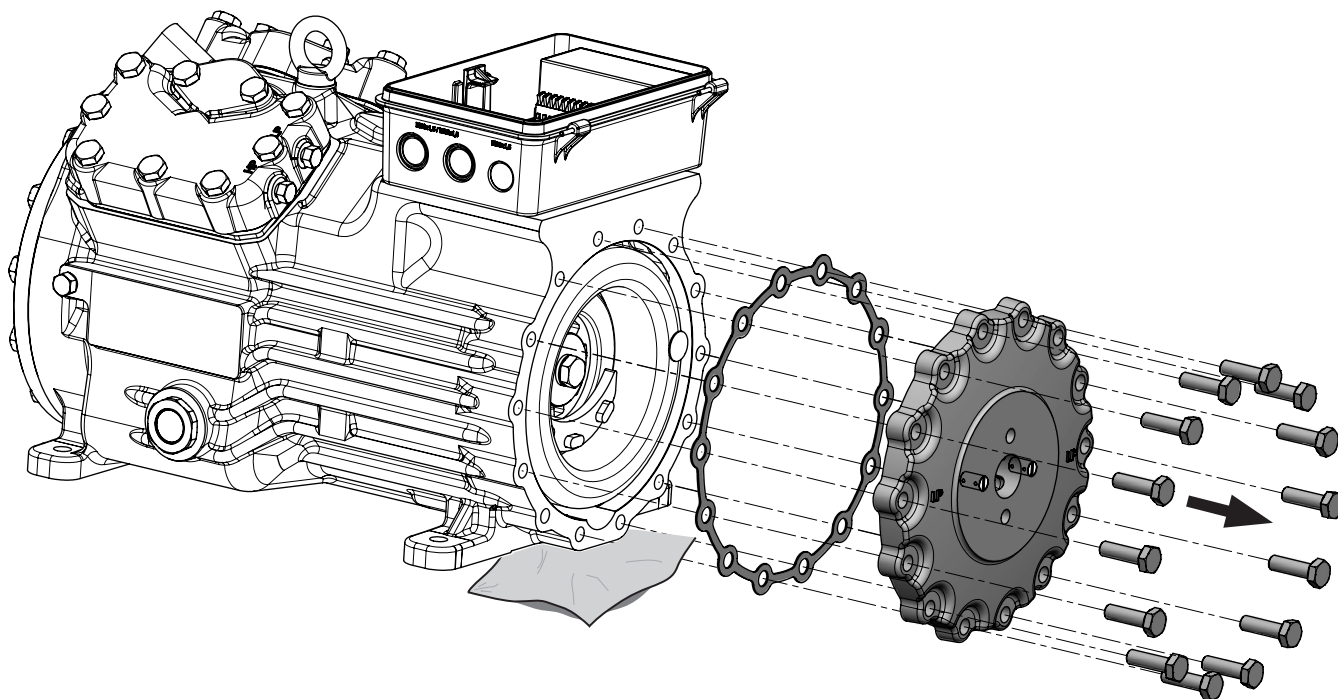

3 | Disassembly of the compressor

4 Remove rotor

Position in parts list

Parts list position: 2130

Tools: Spanner SW 17

Working course

800, 810,
820
790
900

- **Losen rotor screw**
- **Pull off rotor from crankshaft**
- **Take off feather key of crankshaft**
- **Pull of washer between rotor and crankshaft**

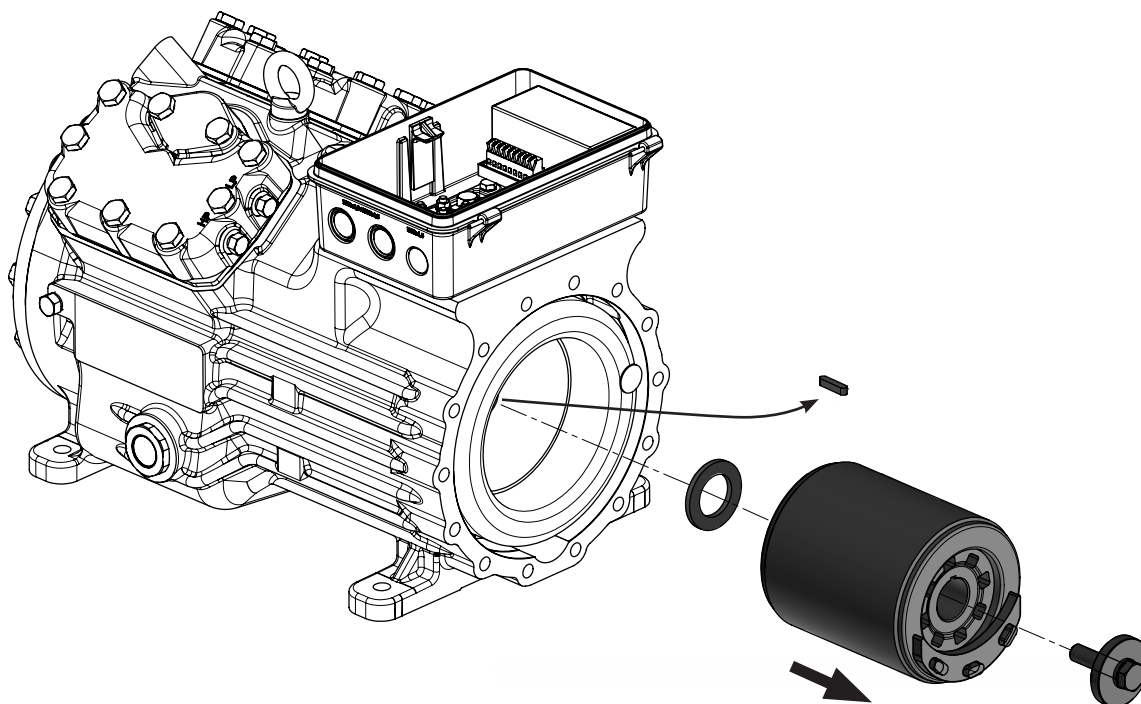

3 | Disassembly of the compressor

5 Remove stator

Position in parts list

Parts list position: 2130

Tools

Spanner SW 13, Allen key

Working course

1010, 1020

- **Losen screw plug and the stator screw below**

- **Pull out stator - Pay attention to the weight!**

Note: For 2 pole compressors the stator cannot be removed because it is built **in while it is still warm.**

①

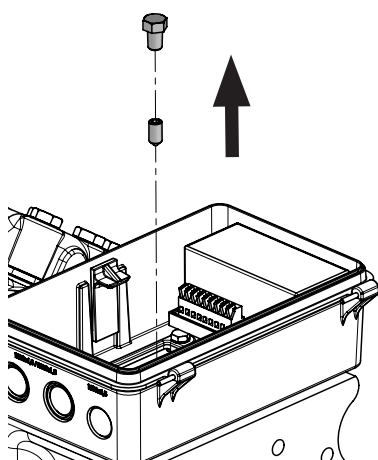

②

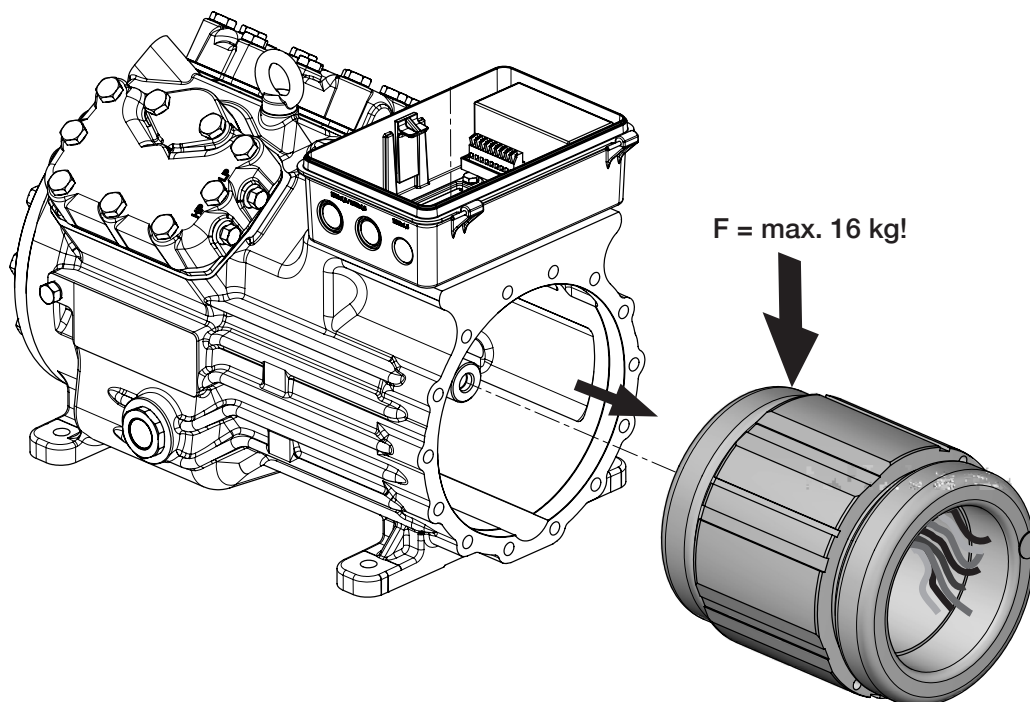

3 | Disassembly of the compressor

6 Remove oil pump and housing cover

Position in parts list

Parts list position: 2020, 2110, 2220

Tools: Spanner SW 13, SW 17, Magnet

Working course

- To collect leaking oil, protect the assembly area with absorbent material.

Dispose of the material environmentally sound afterwards

2020

- Remove oil pump cover

- Remove gears completely with the magnet

- Remove oil sump heater if necessary

480

- Loosen screws on housing cover and unscrew

- Take off housing cover incl. seal

- Remove oil filter

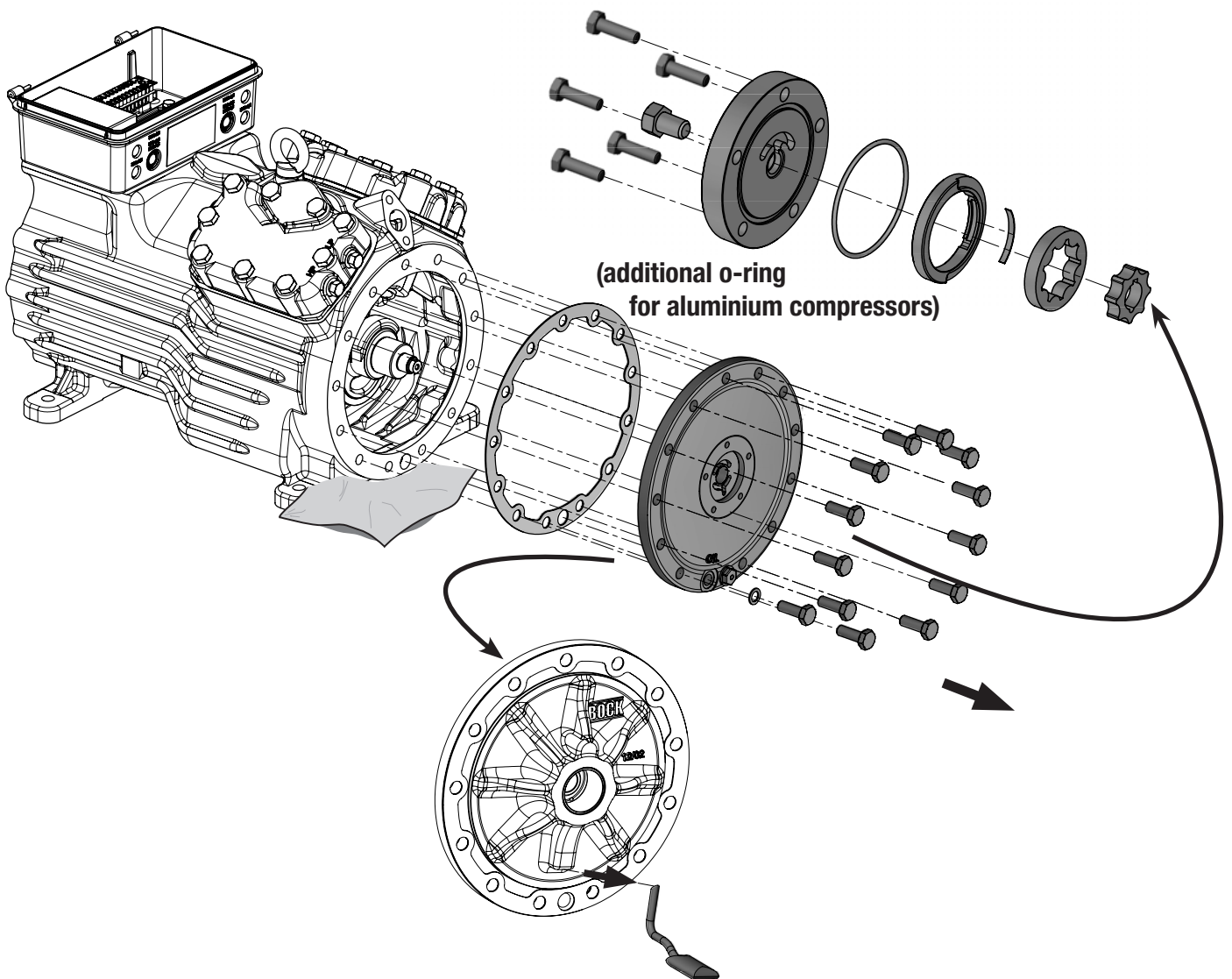

3 | Disassembly of the compressor

7 Remove cylinder cover and valve plates

Position in parts list

Parts list position: 170, 178, 180, 2000

Tools: Spanner SW 17

Working course

- if installed: To not remove thermal protection thermostat and capacity regulator, if necessary disconnect in terminal box

180

170, 70,

60, 50

- **Losen screws at the cylinder cover and unscrew**

- **Remove cylinder cover with seals and valve plate**

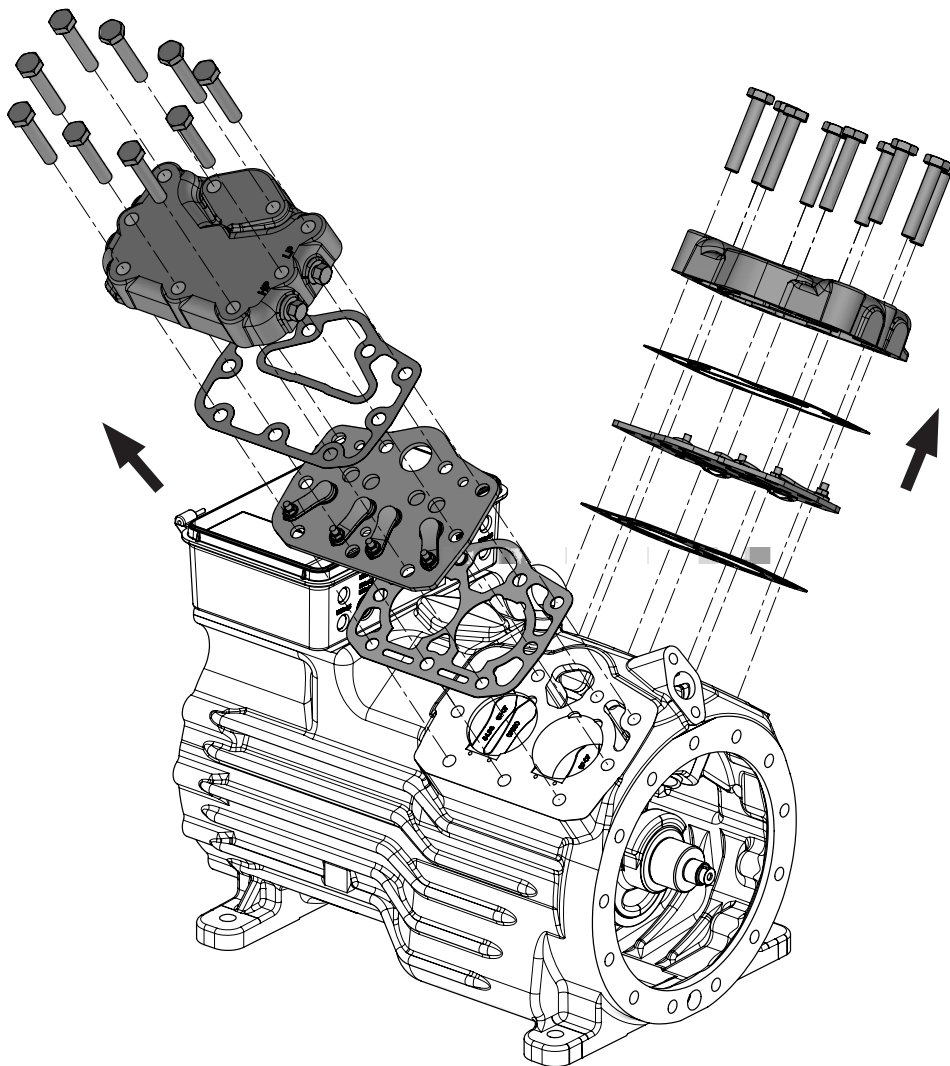

3 | Disassembly of the compressor

8

Remove crankshaft

Position in parts list

Parts list position: 2050

Tools: Spanner SW 17

Working course

320

- Take off feather key of crankshaft on oil pump side

2050

- Release crankshaft of the connecting rod and take it out

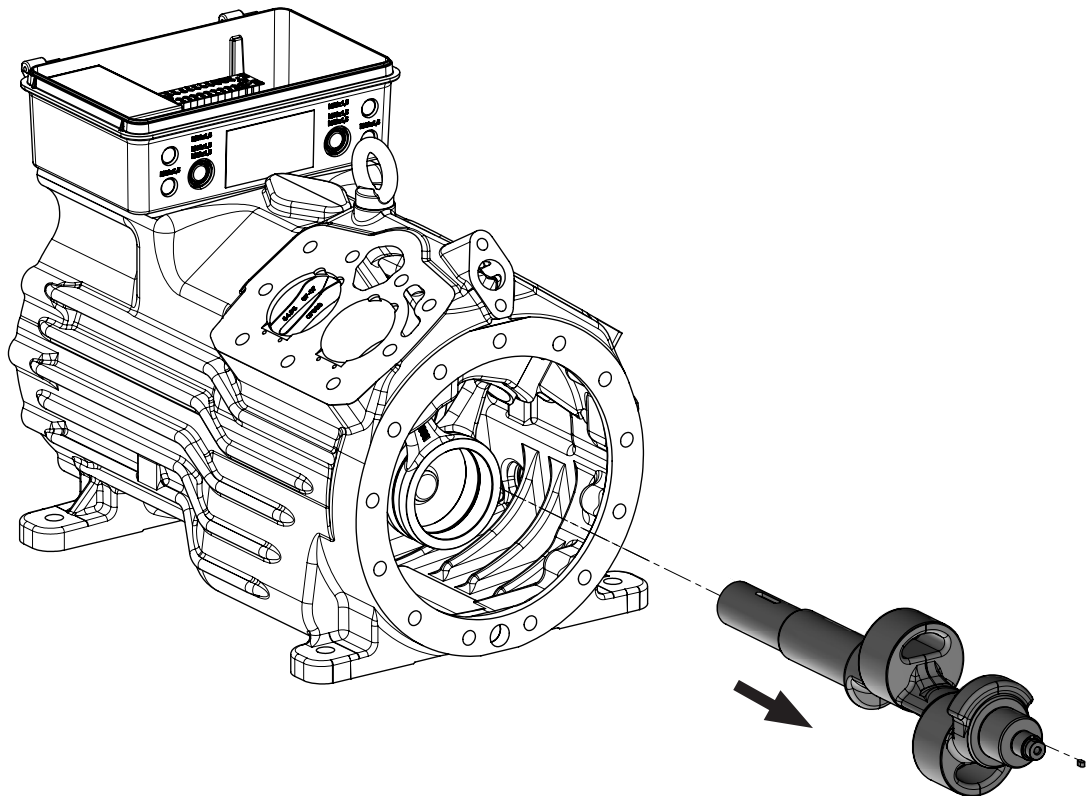

3 | Disassembly of the compressor

9 Remove pistons and connecting rods

Position in parts list

Parts list position: 2040

Tools: Needle-nosed pliers

Working course

- Mark corresponding pistons of cylinder bore
- 2100, 2030 - Push out pistons and connecting rods towards the cylinder cover as far as it will go
- 290, 300 - Remove piston rings
- Take out piston rings towards crankcase
- 280 - Remove circlips of the piston pins with needle-nosed pliers
- 270 - Press out piston pins out of piston

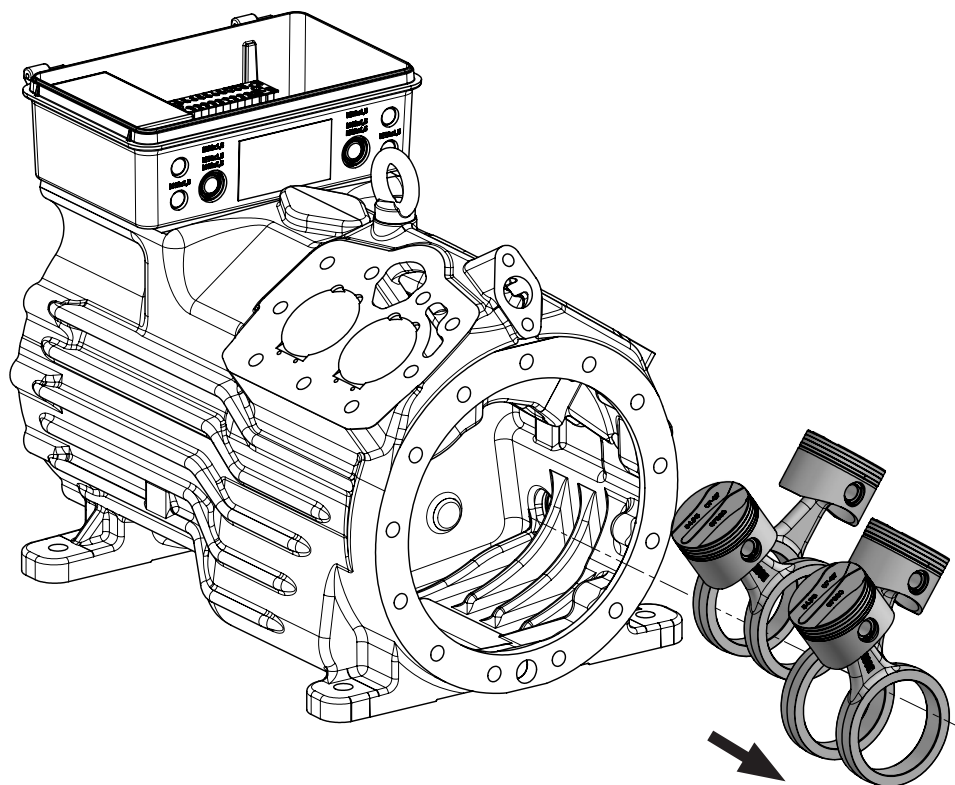

4 | Checking the compressor parts

Checking compressor parts for damages and wear

Before re-using removed compressor parts we recommend that they be checked for usability.

The wear limits listed below should be taken into consideration:

1	Piston - cylinder bore	0,13 mm
2	Connecting rod - piston pin	0,03 mm
3	Crankshaft - connecting rod	0,08 mm

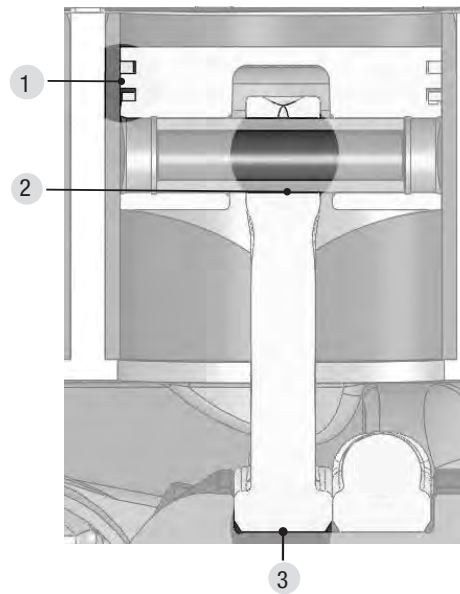

Other components have to be examined according to the following criteria:

• Cylinder liners

The cylinder liners should not have any visible damages in the piston movement area. If there is fluting, the casing should be replaced.

• Crankshaft

The bearing surfaces should not have any damages. The oil channels should be clean so that an unhindered oil flow is ensured.



CAUTION! Remaining oil can cause eye injury!
When compressed air is used, remaining oil can splash out of the oil channels.
Wear protective goggles.



Clean the oil channels with compressed air and check for passage

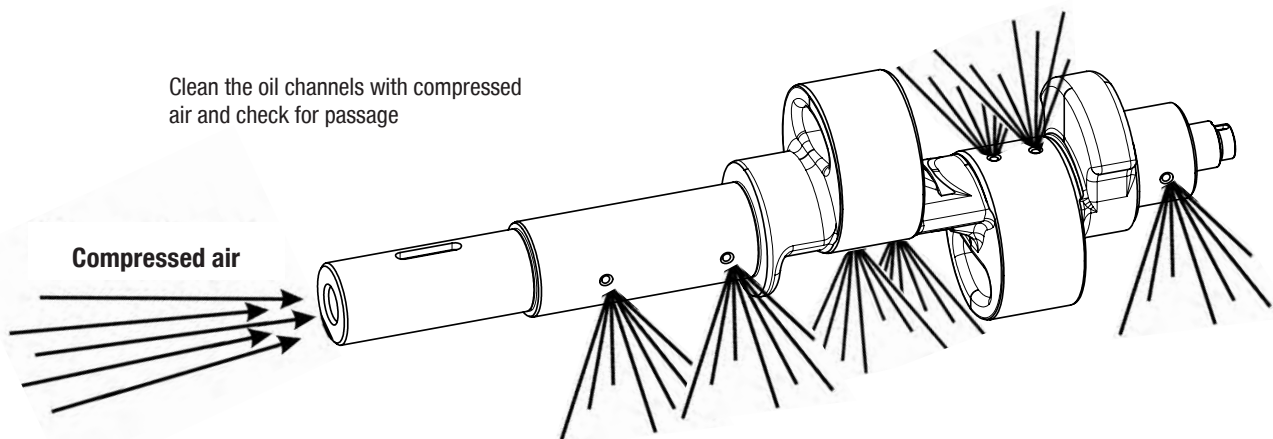

4 | Checking the compressor parts

• Pistons

There should be no visible damages on the piston crown and the piston walls. The grooves for the piston rings must be clean and undamaged. Check the condition of the piston rings for wear, fractures and other irregularities.

• Connecting rods

There should be no damages on bearing surfaces.
The connecting rod shank must be straight.

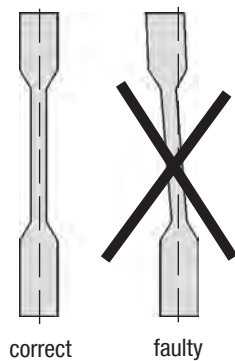

• Valve plates

Suction and pressure lamella must be undamaged and un-deformed. The sealing surfaces must be clean and undamaged, between lamellas and valve plates there should not be any pollution (dirt, swarfs etc.). In case of a damage the valve plate must be replaced completely. Single lamella are not available.

• Oil pump

It must be possible to turn the oil pump by hand (turning to the left and to the right).
In the removed conditioning the reversing device of the oil pump must switch over audibly.

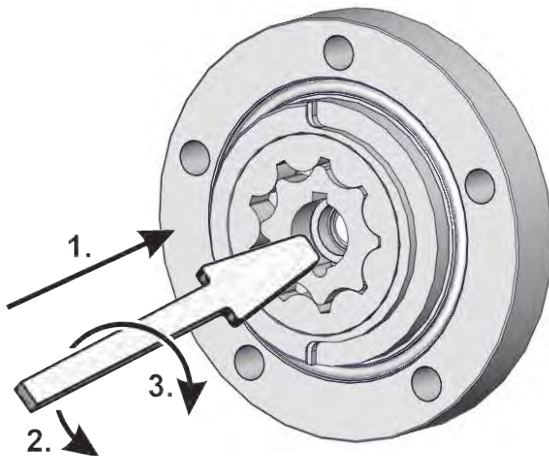

4 | Checking the compressor parts

- **Oil filter / suction filter**

The filter screen must be in an undamaged condition. Dirt and residues have to be removed. If necessary, the filter have to be cleaned with compressed air or replaced with new ones.

In case of larger compressor damages which necessitate a complete disassembly of the compressor, we recommend in principle the replacement of the valve plates, the piston rings and all seals. Thus, concealed defects of parts which have been in operation may be prevented.

5 | Assembly of compressor

Assembly of compressor

The assembly of the compressor is explained in separate steps on the following pages. The indicated parts list positions refer to the spare parts lists, repair set lists, special accessories part lists and is available online at www.gea.com. Follow the stated tightening torques of the screws!

You can find the exploded drawing at the end of the maintenance manual.

Preparation: Necessary tools

Pos.	Tool	Size
1	Spanner	SW 10, 13, 14, 17, 19
2	Allen key	6 mm, 10 mm
3	Needle-nosed pliers	
4	Torque spanner	
5	Piston ring plier	

5 | Assembly of compressor

1 Assembly of the pistons / connection

Position in parts list

Parts list position: 2040

Tools: Needle-nosed pliers

Working course

2100, 270,
280

- Assemble piston and connecting rod with piston pin, use some oil for easier assembly
- Mount circlips with pliers on both sides of the piston pins

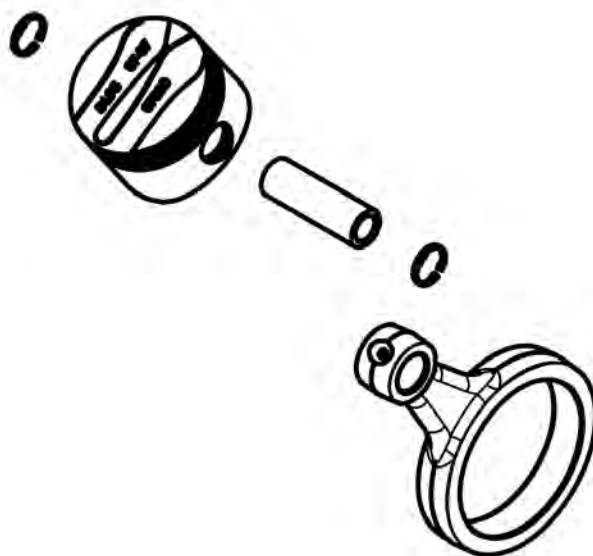

5 | Assembly of compressor

2 Fitting the piston / connecting

Position in parts list

Parts list position: 2040

Tools: Piston ring plier

Working course

We recommend cleaning the housing from the inside before assembly

- Apply a little oil to the cylinder bore
- Insert pistons/connecting rods from below into the cylinder liners
 - > Pay attention to the correct assembly position (suction fin grooves)
- Install oil scraper rings in the lower groove and pressure rings in the upper groove
 - > Fit with the marking "TOP" facing upwards
 - > The butt joints of the piston rings have to be installed min. 30° twisted to each other and may not be lying upon each other
- Push piston rings with piston plier onto the piston and push piston into the housing

290, 300



Oil scraper ring

Compression ring

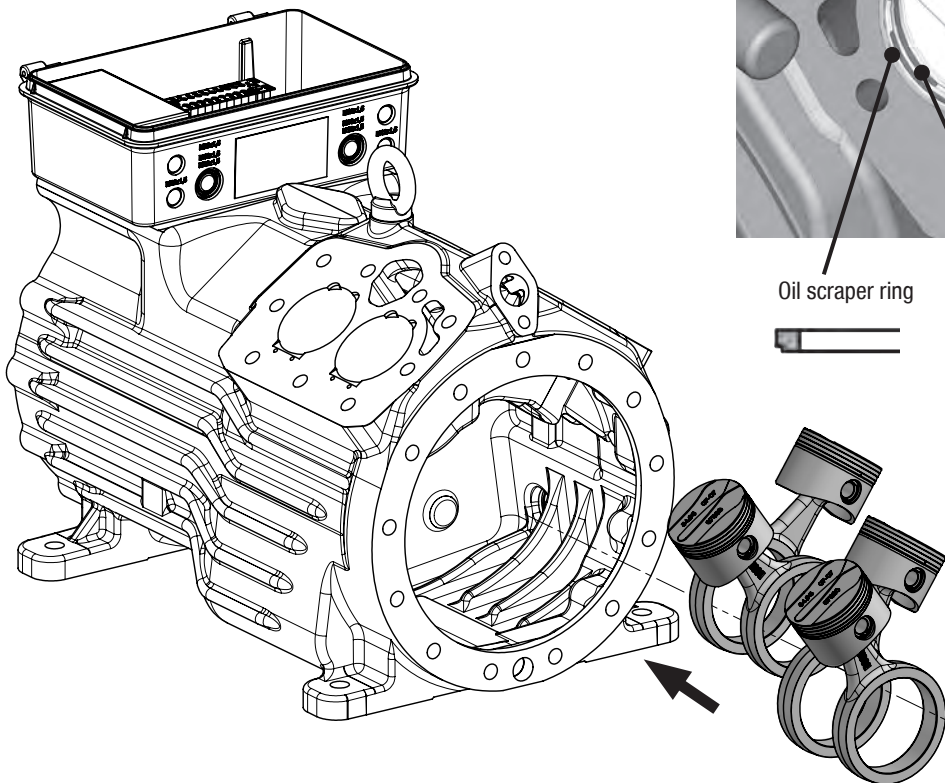

5 | Assembly of compressor

3 Fitting the crankshaft

Position in parts list

Parts list position: 2050

Tools:

Working course

- Apply bearing surface with oil
- Insert crankshaft.

Important: Alle connecting rods have to be moved axially and radially on the crankshaft

- Insert feather key on oil pump side

320

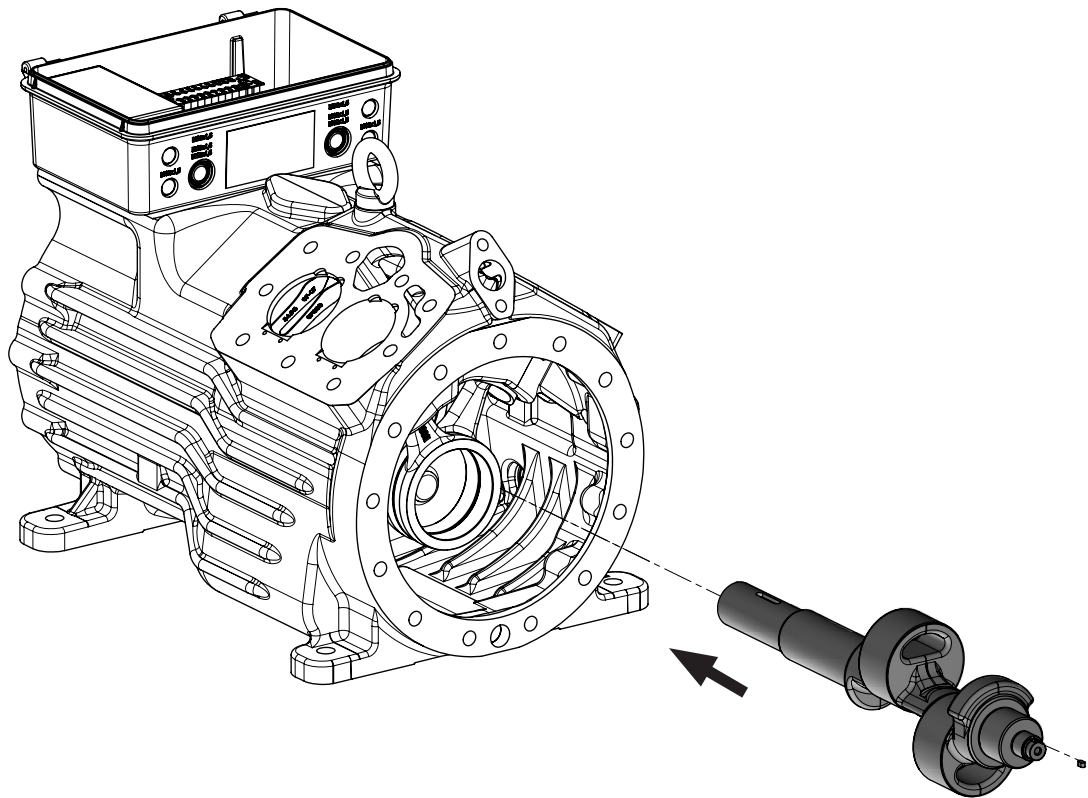

5 | Assembly of compressor

4 Installation of cylinder cover

Position in parts list

Parts list position: 170, 180, 2000

Tools: Spanner SW 17

Working course

50, 60, 70,
170

- Slightly oil seals

- Install seals below, valves plates, seals above and cylinder cover together

180

- Tighten the screws crosswise

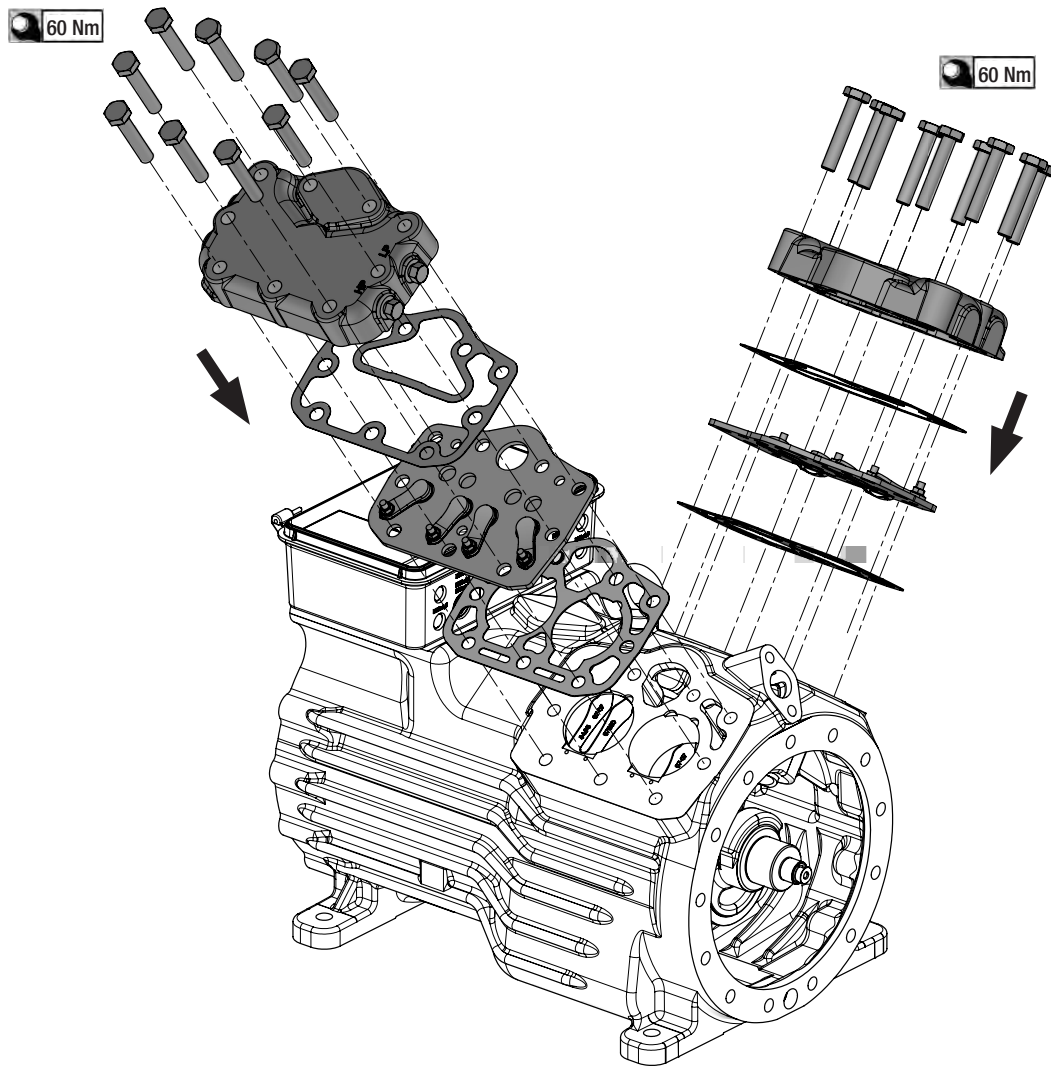

5 | Assembly of compressor

5 Install oil pump and housing cover

Position in parts list

Parts list position: 2110

Tools: Spanner SW 10, 17

Working course

480

2020

- The sealing surfaces have to be clean. Slightly oil seals
- Screw housing cover tightly. Tighten the screws (M10 x 30) crosswise
- Install oil pump. The o-ring seal has to lie in the groove
- Install oil sump heater if necessary

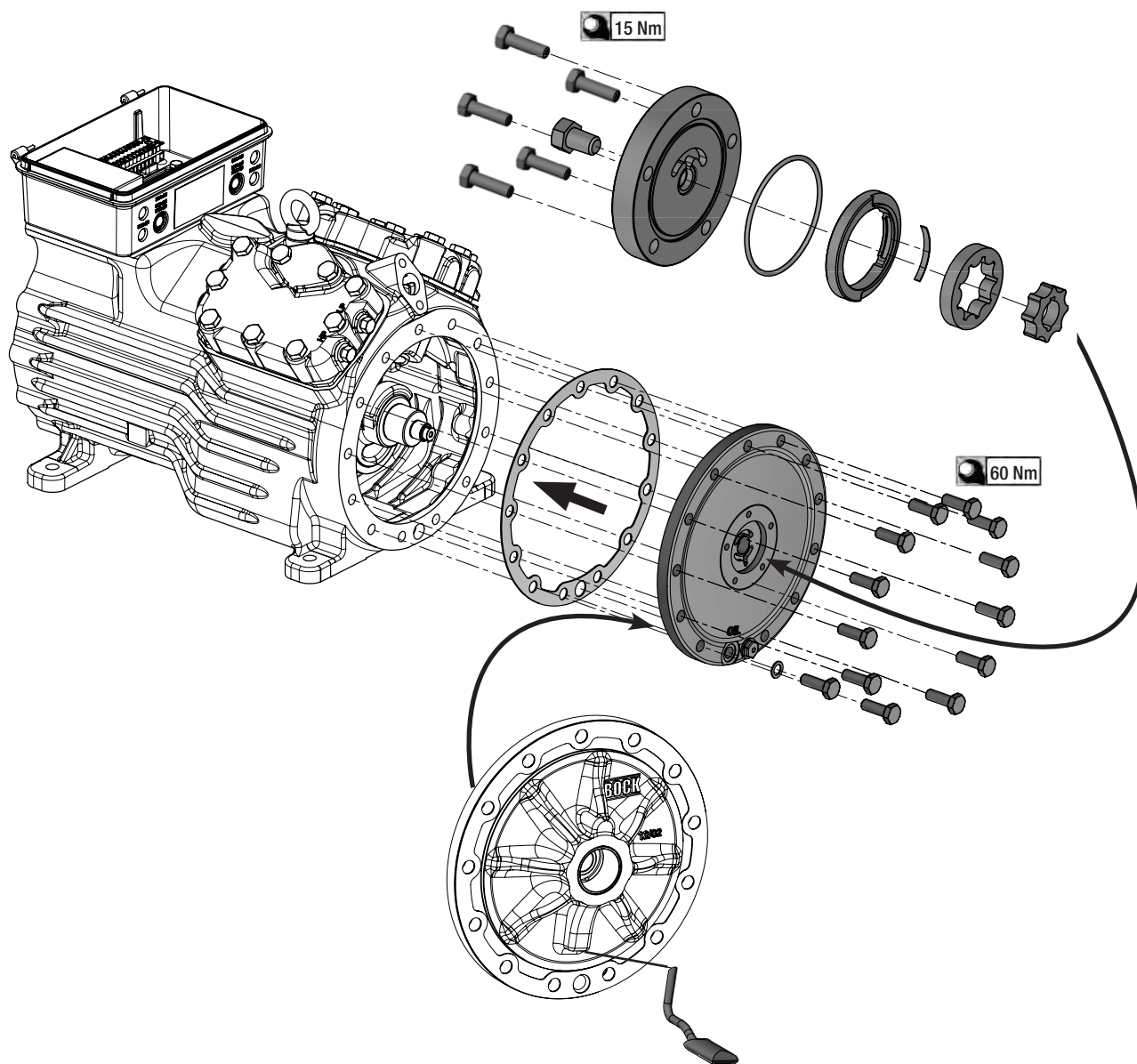

5 | Assembly of compressor

6 Install stator

Position in parts list

Parts list position: 2130

Tools: Spanner SW 13, SW 17, needle-nosed pliers

Working course

- 1179 - Regard alignment of feather key - Stator, the parts can only be installed aligned
- 1020 - Push stator into the housing as far as it goes
- 1010 - Screw stator screw in. The hardening time of the thread coating is 6 hours.
Use stator screw only once!
- Screw in screw plug

①

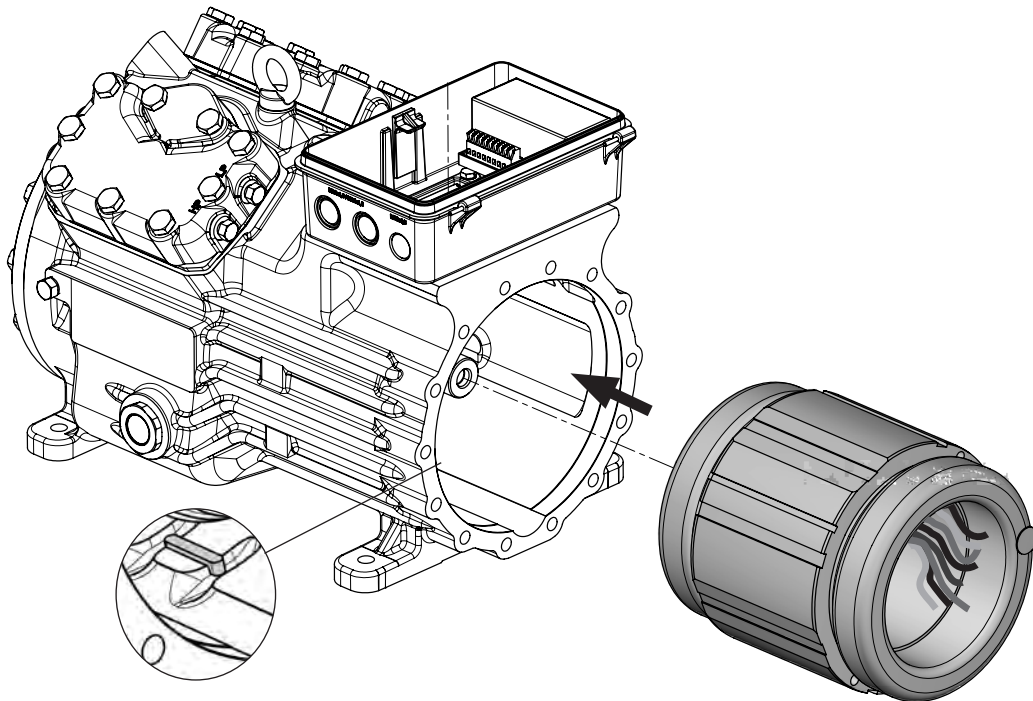

②

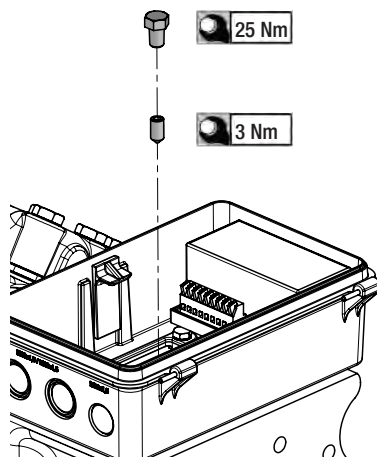

5 | Assembly of compressor

7 Install terminal board

Position in parts list | Parts list position: 2150, 1055, 1060, 1065, 1071
Tools: Spanner SW 13

Working course
1055, 1065 - Slightly oil seals
2150 - Install terminal board and PTC-terminal board

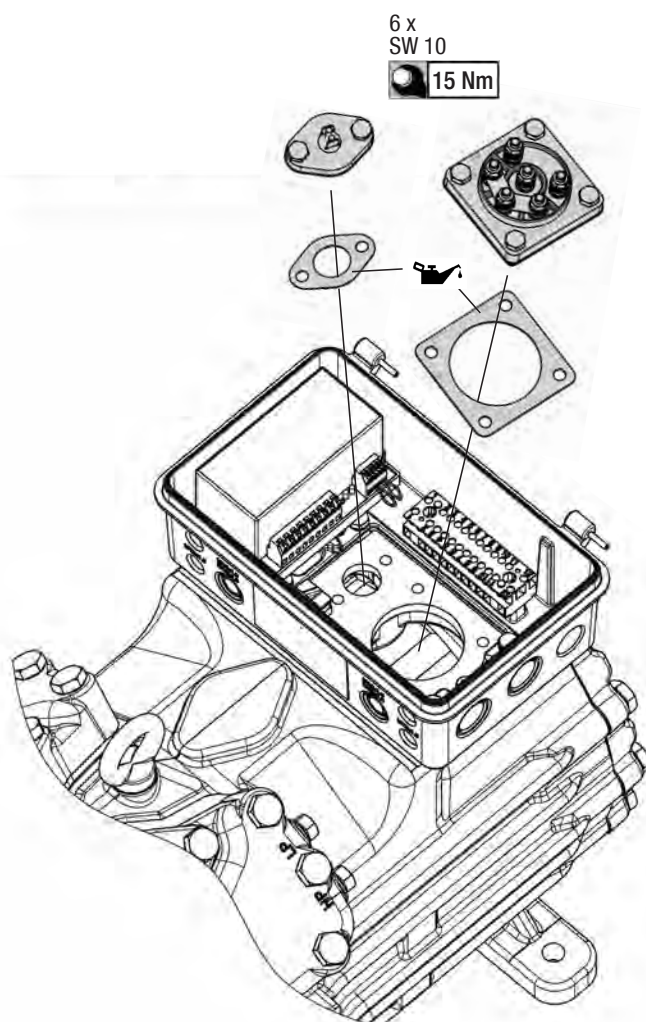

5 | Assembly of compressor

8

Wire terminal board

Position in parts list

Parts list position: 2150

Tools: Spanner SW 13

Working course

- After wiring the terminal board check the function of all phases with a measuring device

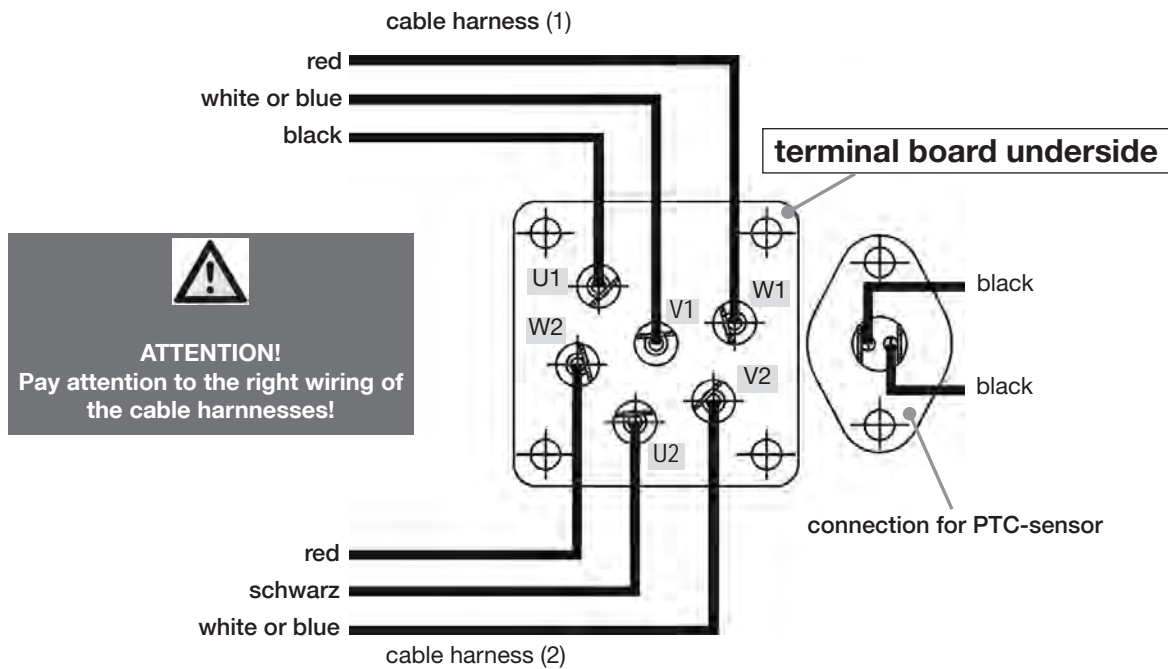

5 | Assembly of compressor

9 Install rotor

Position in parts list

Parts list position: 2130

Tools: Spanner SW 17

Working course

- 900 - Push pulley on the crankshaft as far as it goes
- 790 - Insert feather key into the crankshaft
- 800 - Push the rotor on the crankshaft
- 810, 820 - Tighten screw with pulley and spring washer (and bolt spacer if necessary)

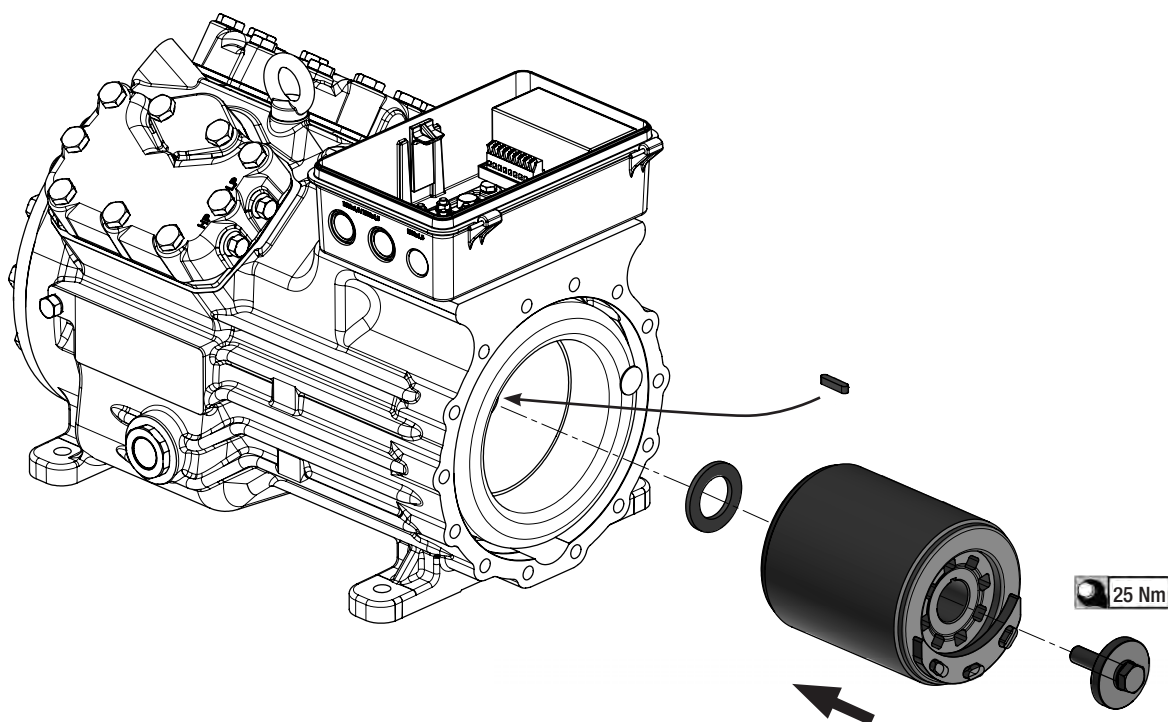

5 | Assembly of compressor

10 Install housing cover suction side

Position in parts list

Parts list position: 720, 721, 740

Tools: Spanner SW 17

Working course

721

- Slightly oil seals

720, 740

- Screw the housing cover incl. seal, tighten screws crosswise

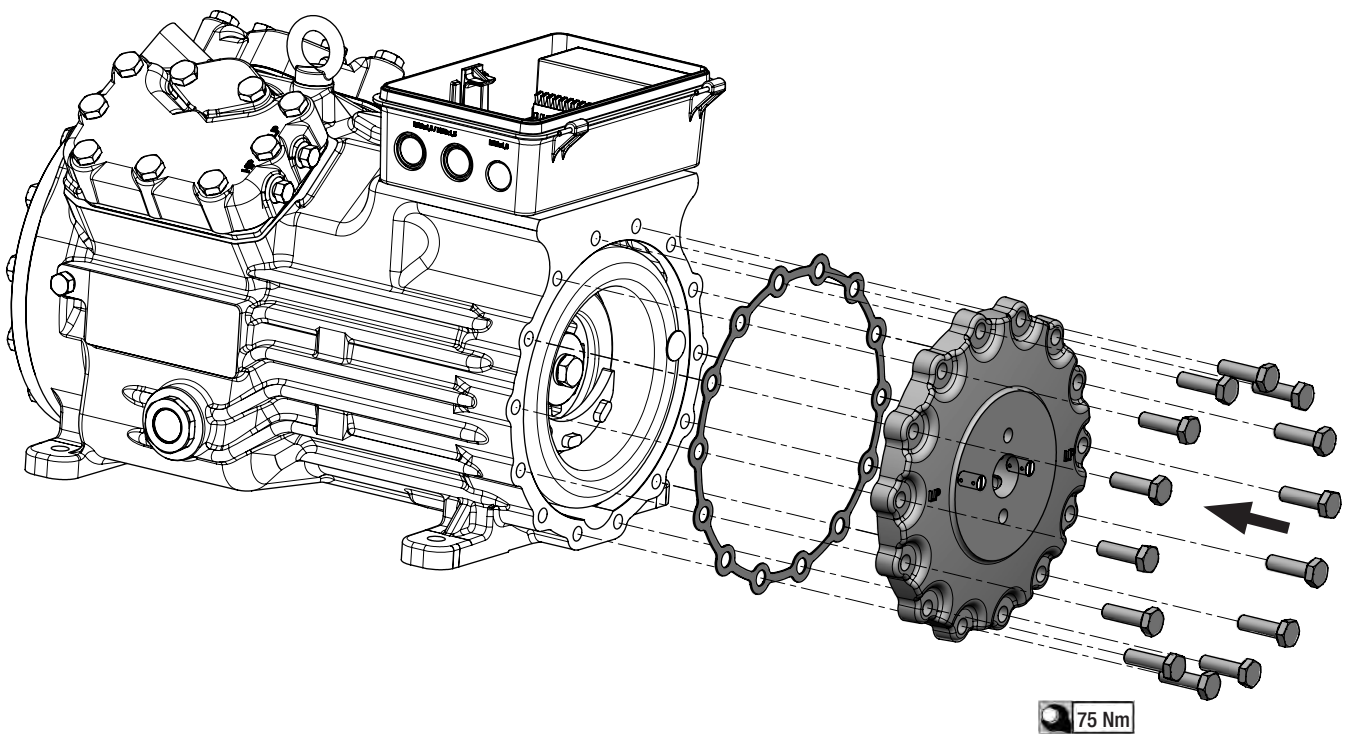

5 | Assembly of compressor

11 Finish installation and wire

Position in parts list

Parts list position:

Tools:

Working course

- Do the electrical installation according to the diagram in the terminal box - Pay attention to the installation instruction of the compressor!
- Close the cover at the terminal box
- Do the next step, such as commissioning, according to the installation instructions of the compressor

6 | Exploded drawing

HG34e cast iron, HG34P 2-pole cast iron, HG34P HC-compressors

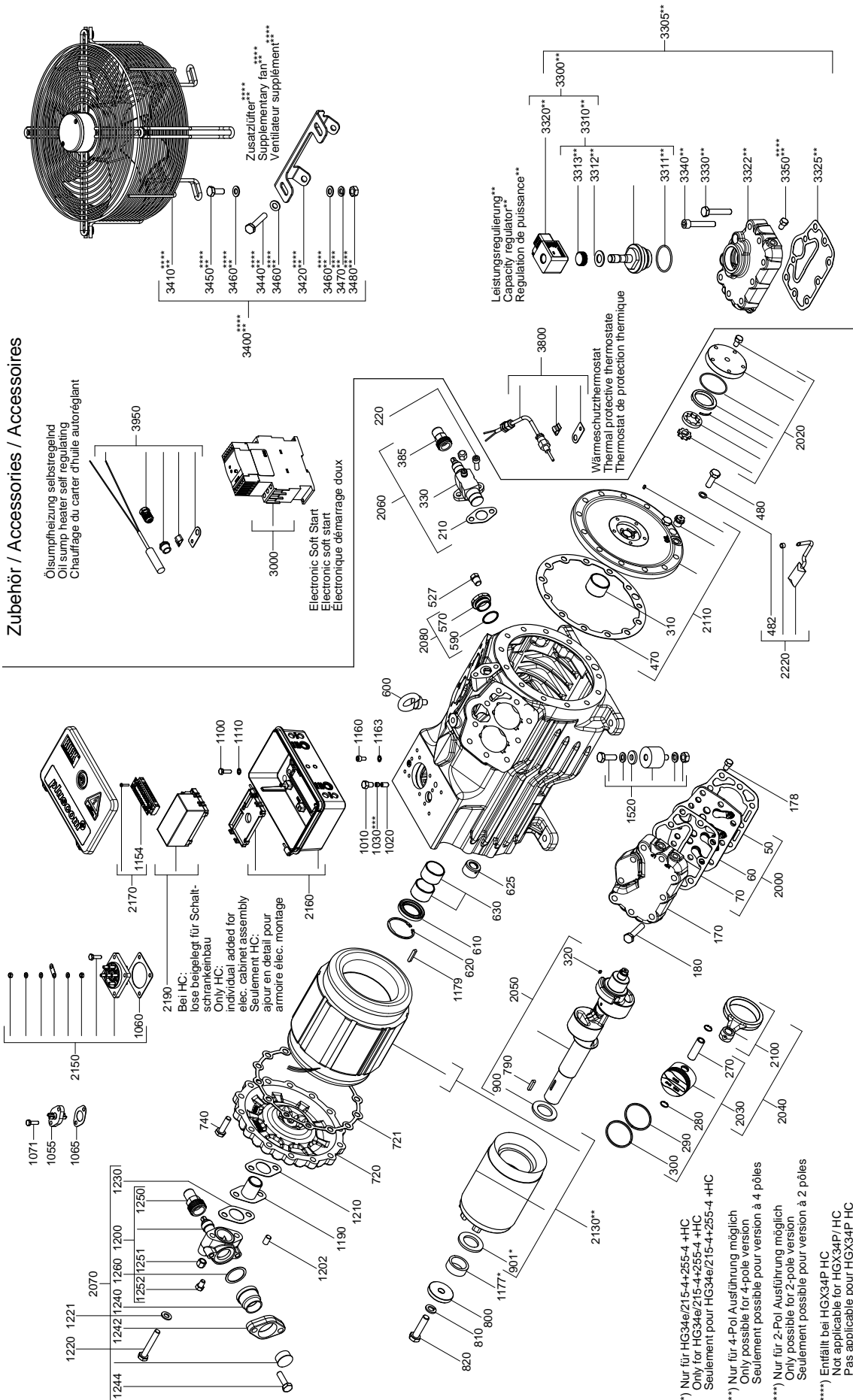

*) Nur für HG34e/215-4+255-4 +HC
Only for HG34e/215-4+255-4 +HC
Seulement pour HG34e/215-4+255-4 +HC

**) Nur für 4-Pol Ausführung möglich
Only possible for 4-pole version
Seulement possible pour version à 4 pôles

***) Nur für 2-Pol Ausführung möglich
Only possible for 2-pole version
Seulement possible pour version à 2 pôles

****) Entfällt bei HG34P HC
Not applicable for HG34P/HC
Pas applicable pour HG34P HC

6 | Exploded drawing

HG34e aluminium compressor 4-pole

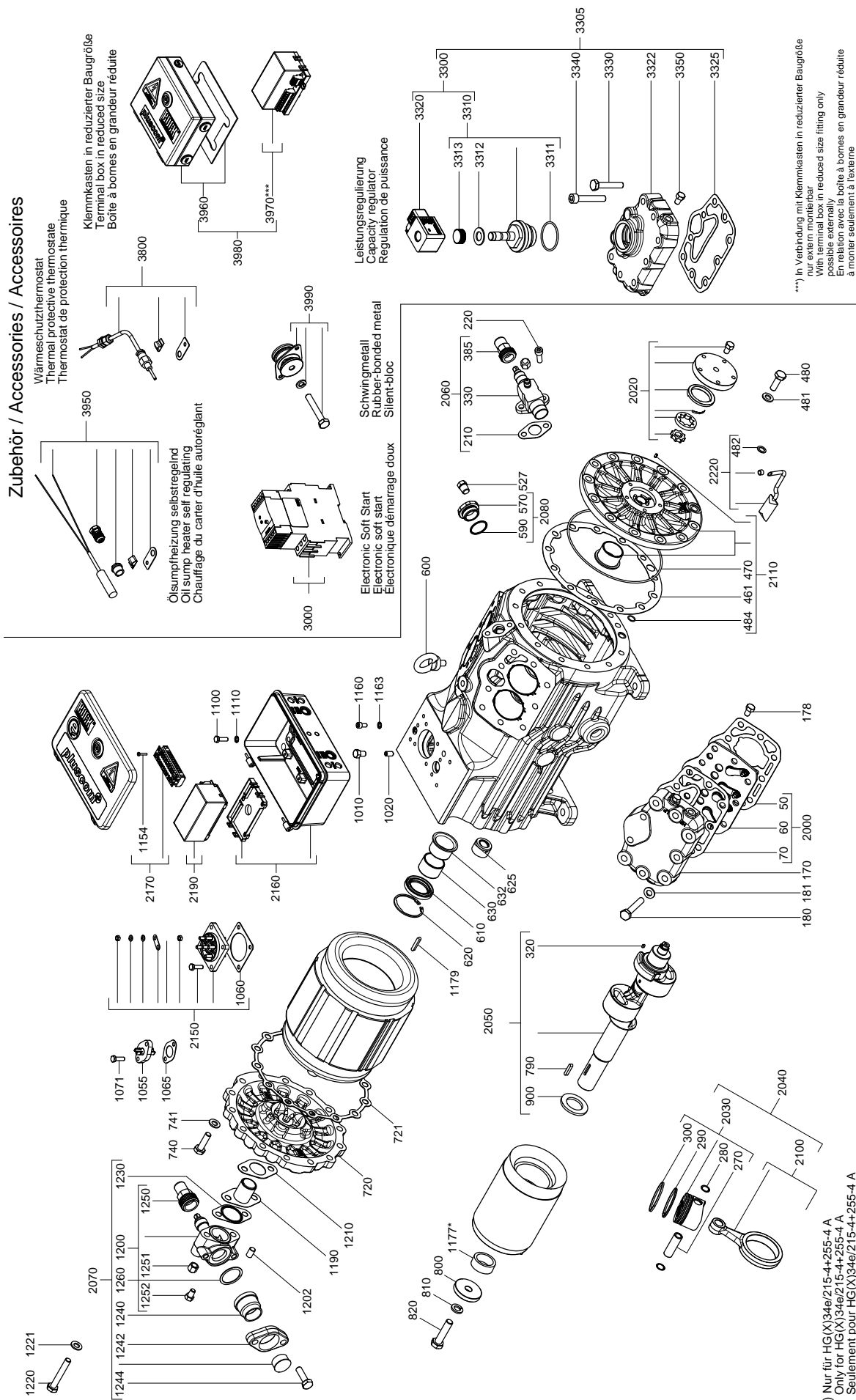

***) In Verbindung mit Klemmkasten in reduzierter Baugröße
In connection with terminal box in reduced size fitting only
With terminal box in reduced size fitting only
En relation avec la boîte à bornes en grandeur réduite
à monter seulement à l'exterieur

*) Nur für HG(X)34e/215-4+255-4 A
Only for HG(X)34e/215-4+255-4 A
Seulement pour HG(X)34e/215-4+255-4 A

6 | Exploded drawing

HG34P aluminium compressor 2-pole and K-Design

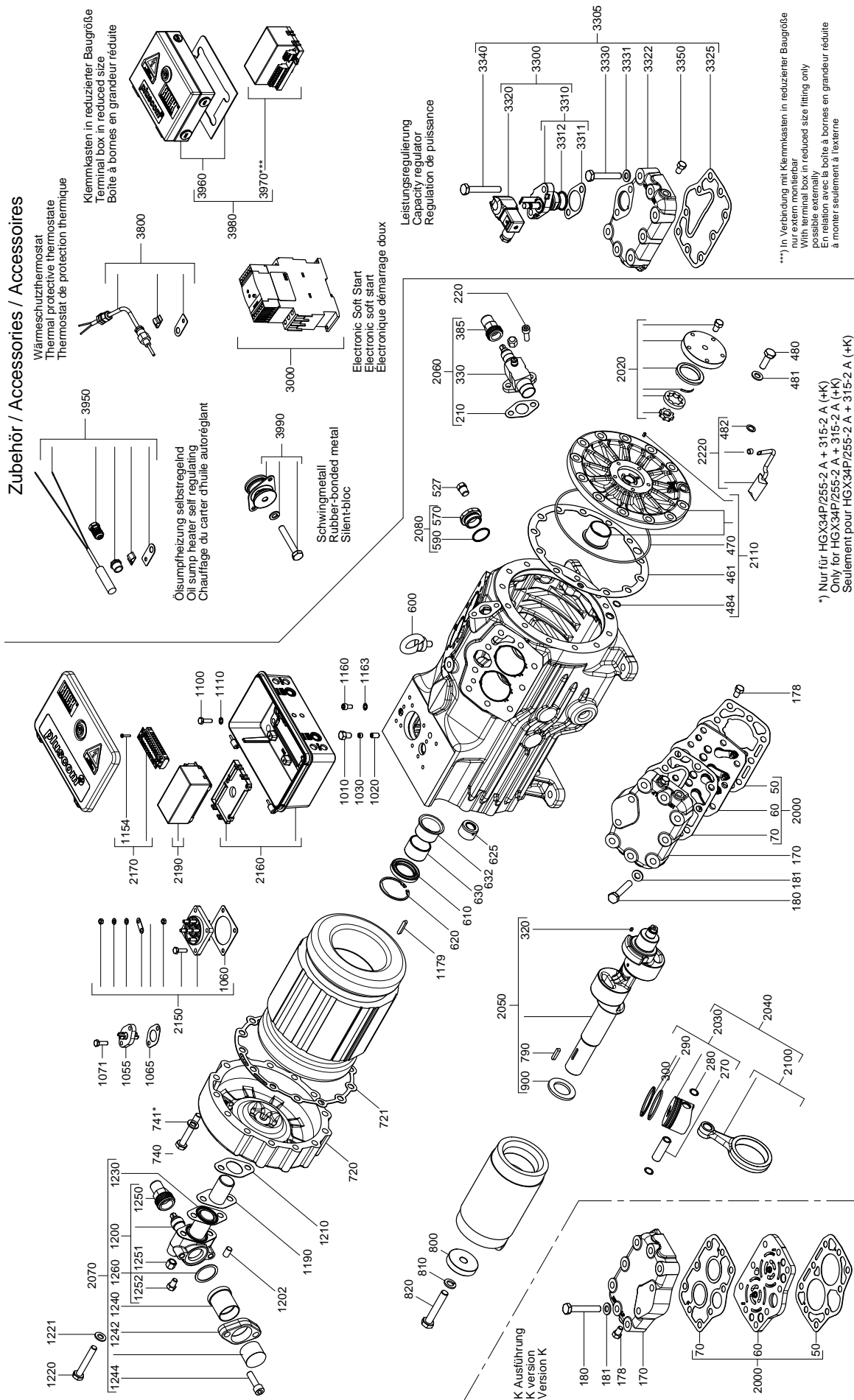

6 | Exploded drawing

HG34e for R407C, HG34P for R410A

Zubehör / Accessoires /
Accessoires

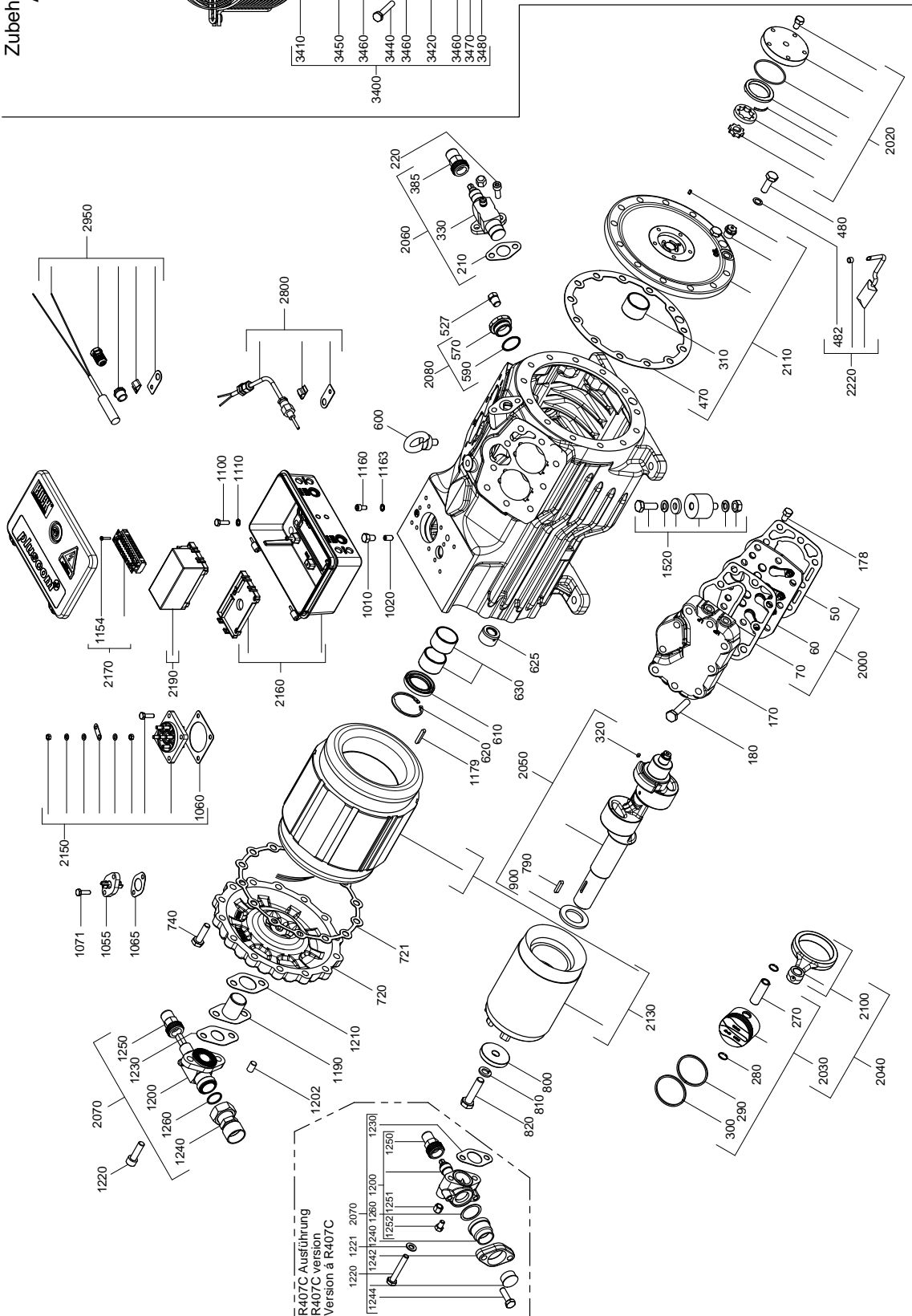
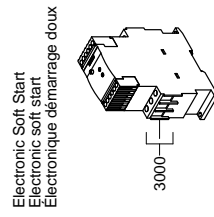
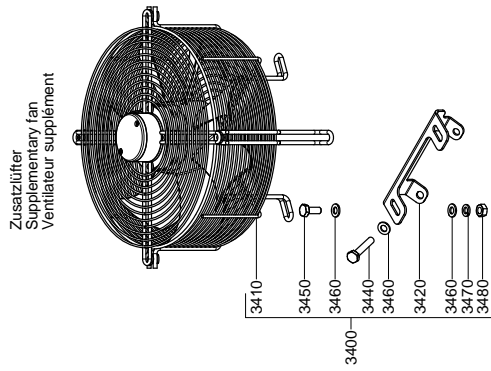

R407C Ausführung
R407C version
Version à R407C



We live our values.

Excellence • Passion • Integrity • Responsibility • GEA-versity

GEA Group is a global engineering company with multi-billion euro sales and operations in more than 50 countries. Founded in 1881, the company is one of the largest providers of innovative equipment and process technology. GEA Group is listed in the STOXX® Europe 600 index.

GEA Refrigeration Technologies

GEA Bock GmbH

Benzstraße 7, 72636 Frickenhausen, Germany
Phone: +49 7022 9454-0, Fax: +49 7022 9454-137
refrigeration@gea.com, www.gea.com