

## Bock Compressor HG12P

### Assembly instructions

HG12P/75-4  
HG12P/90-4  
HG12P/110-4

HG12P/60-4 S  
HG12P/75-4 S  
HG12P/90-4 S  
HG12P/110-4 S

HGX12P/75-4  
HGX12P/90-4  
HGX12P/110-4

HGX12P/60-4 S  
HGX12P/75-4 S  
HGX12P/90-4 S  
HGX12P/110-4 S

# About these instructions

Read these instructions before assembly and before using the compressor. This will avoid misunderstandings and prevent damage. Improper assembly and use of the compressor can result in serious or fatal injury.

Observe the safety instructions contained in these instructions.

These instructions must be passed onto the end customer along with the unit in which the compressor is installed.

## **Manufacturer**

GEA Bock GmbH  
72636 Frickenhausen

## **Contact**

GEA Bock GmbH  
Benzstraße 7  
72636 Frickenhausen  
Germany

**GB**

Telephone +49 7022 9454 0  
Fax +49 7022 9454 137  
bock@gea.com  
www.bock.de

# Contents





Page

<b>1</b>	<b>Safety</b>	<b>4</b>
1.1	Identification of safety instructions	
1.2	Qualifications required of personnel	
1.3	General safety instructions	
1.4	Intended use	
<b>2</b>	<b>Product description</b>	<b>6</b>
2.1	Short description	
2.2	Name plate	
2.3	Type key	
<b>3</b>	<b>Areas of application</b>	<b>8</b>
3.1	Refrigerants	
3.2	Oil charge	
3.3	Limits of application	
<b>4</b>	<b>Compressor assembly</b>	<b>10</b>
4.1	Setting up	
4.2	Pipe connections	
4.3	Pipes	
4.4	Laying suction and pressure lines	
4.5	Operating the shut-off valves	
4.6	Operating mode of the lockable service connections	
<b>5</b>	<b>Electrical connection</b>	<b>13</b>
5.1	Information for contactor and motor contactor selection	
5.2	Connection of the driving motor	
5.3	Circuit diagram for direct start 230 V $\Delta$ / 400 V Y	
5.4	Start unloader	
5.5	Electronic trigger unit MP 10	
5.6	Connection of the electronic trigger unit MP 10	
5.7	Functional test of the electronic trigger unit MP 10	
<b>6</b>	<b>Commissioning</b>	<b>18</b>
6.1	Preparations for start-up	
6.2	Pressure strength test	
6.3	Leak test	
6.4	Evacuation	
6.5	Refrigerant charge	
6.6	Start-up	
6.7	Avoiding slugging	
6.8	Connection of oil level regulator	
<b>7</b>	<b>Maintenance</b>	<b>20</b>
7.1	Preparation	
7.2	Work to be carried out	
7.3	Spare parts recommendation	
7.4	Accessories	
7.5	Extract from the lubricants table	
7.6	Decommissioning	
<b>8</b>	<b>Technical data</b>	<b>22</b>
<b>9</b>	<b>Dimensions and connections</b>	<b>23</b>
<b>10</b>	<b>Declaration of conformity and installation</b>	<b>24</b>
<b>11</b>	<b>Service</b>	<b>25</b>

GB

# 1| Safety

## 1.1 Identification of safety instructions:

	<b>DANGER!</b>	Indicates a dangerous situation which, if not avoided, will cause immediate fatal or serious injury.
	<b>WARNING!</b>	Indicates a dangerous situation which, if not avoided, may cause fatal or serious injury.
	<b>CAUTION!</b>	Indicates a dangerous situation which, if not avoided, may cause fairly severe or minor injury.
	<b>ATTENTION!</b>	Indicates a situation which, if not avoided, may cause property damage.
	<b>INFO!</b>	Important information or tips on simplifying work.

GB

## 1.2 Qualifications required of personnel

	<b>WARNING!</b>	<p>Inadequately qualified personnel poses the risk of accidents, the consequence being serious or fatal injury. Work on compressors must therefore only be performed by personnel with the qualifications listed below:</p> <ul style="list-style-type: none"><li>• For example, a refrigeration technician, refrigeration mechatronics engineer. As well as professions with comparable training, which enable personnel to assemble, install, maintain and repair refrigeration and air-conditioning systems. Personnel must be capable of assessing the work to be carried out and recognising any potential dangers.</li></ul>
---	-----------------	--

## 1.3 General safety instructions

	<b>WARNING!</b>	<ul style="list-style-type: none"><li>• Refrigerating compressors are pressurised machines and therefore require particular caution and care in handling.</li><li>• Risk of burns! Depending on the operating conditions, surface temperatures of over 60 °C on the pressure side or below 0 °C on the suction side can be reached.</li><li>• The maximum permissible overpressure must not be exceeded, even for testing purposes.</li></ul>
---	-----------------	---

09652-09.2013-DGbFEI

# 1| Safety

## 1.4 Intended use

These assembly instructions describe the standard version of the HG12P manufactured by Bock. The compressor is intended for use in refrigeration systems in compliance with the limits of application. Only the refrigerant specified in these instructions may be used.

**Any other use of the compressor is prohibited!**



**WARNING! The compressor may not be used in potentially explosive environments!**

The Bock refrigerating compressor named in the title is intended for installing in a machine (within the EU according to the EU Directives 2006/42/EC Machinery Directive, 97/23/EC Pressure Equipment Directive and 2006/95/EC – Low Voltage Directive).

Commissioning is only permissible if the compressor has been installed in accordance with these assembly instructions and the entire system into which it is integrated has been inspected and approved in accordance with legal regulations.

GB

## 2| Product description

### 2.1 Short description

- Semi-hermetic two-cylinder reciprocating compressor with oil pump lubrication.
- Suction gas cooled drive motor.

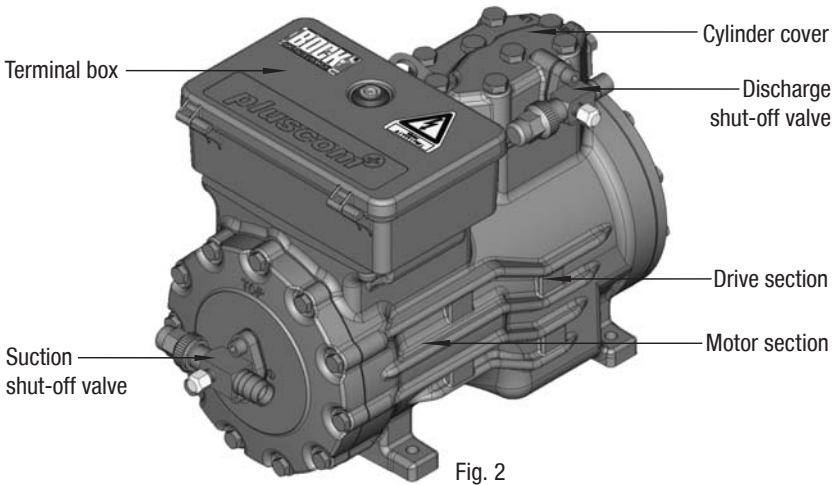
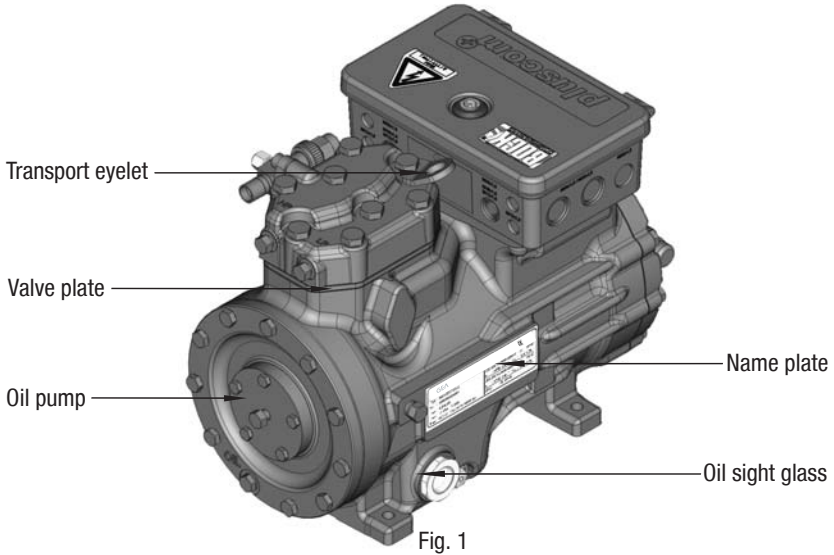

Dimension and connection values can be found in Chapter 9

## 2| Product description

### 2.2 Name plate (example)



 <b>GEA Bock GmbH</b> 72636 Frickenhausen, Germany			
1	Typ : HGX12P/110-4S	6	220-240VΔ/380-420VY -3- 50HZ
2	Nr. : AS35830A001	7	n : 1450 min <sup>-1</sup> V <sub>th.</sub> : 9,4 m <sup>3</sup> /h
3	I <sub>max.</sub> : 10,6/6,1A	8	265-290VΔ/440-480VY -3- 60HZ
4	I <sub>block.</sub> Δ: 45A Y: 26A	9	n : 1740 min <sup>-1</sup> V <sub>th.</sub> : 11,3 m <sup>3</sup> /h
5	p <sub>max.</sub> : ND(LP) / HD(HP)=19/28 bar	10	IP65
		11	Öl: SE 55
		12	
		13	

Fig. 3

1	Type designation	6	Voltage, circuit, frequency
2	Machine number	7	Nominal rotation speed } 50 Hz
3	maximum operating current	8	Displacement
4	Starting current (rotor blocked)	9	Voltage, circuit, frequency
5	ND (LP): max. admissible operating pressure (g) Low pressure side	10	Nominal rotation speed } 60 Hz
	HD (HP): max. admissible operating pressure (g) High pressure side	11	Displacement
		12	Oil type filled at the factory
		13	Terminal box protection type



**Observe the limits of application diagrams!**



**Electrical accessories can change the IP protection class!**

GB

### 2.3 Type key (example)

**HG X 12 P / 110-4 S**

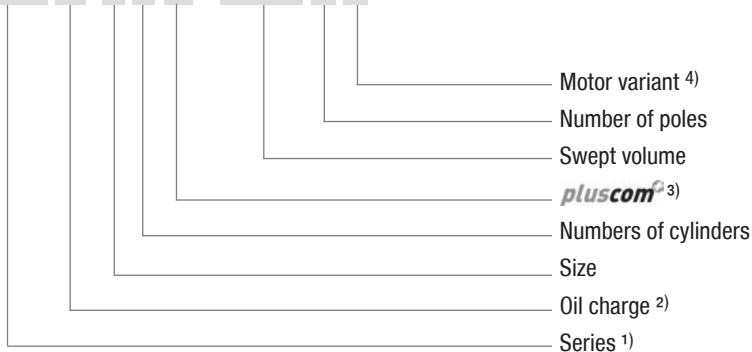

- 1) HG - Hermetic Gas-cooled (suction gas-cooled) for the normal- / air conditioning applications
- 2) X - Ester oil charge (HFC refrigerant, e.g. R134a, R404A/R507, R407C)
- 3) Additional declaration for Pluscom compressors
- 4) S - More powerful motor, e.g. for air-conditioning applications

# 3| Areas of application

## 3.1 Refrigerants

- HFKW / HFC: R134a, R404A/R507, R407C
- (H)FCKW / (H)CFC: R22

## 3.2 Oil charge

- The compressors are filled at the factory with the following oil type:
  - for R134a, R404A/R507, R407C FUCHS Reniso Triton SE 55
  - for R22 FUCHS Reniso SP 46

Compressors with ester oil charge (FUCHS Reniso Triton SE 55) are marked with an X in the type designation (e.g. HGX12P/110-4).



**INFO!** For refilling, we recommend the above oil types.  
Alternatives: see lubricants table, Chapter 7.5.



**ATTENTION!** The oil level must be in the visible part of the sight glass; damage to the compressor is possible if over-filled or underfilled!

max. oil level

min. oil level

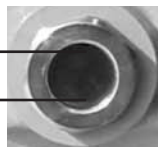

Fig. 4

GB

## 3.3 Limits of application



- ATTENTION!**
- Compressor operation is possible within the operating limits shown in the diagrams. Please note the significance of the shaded areas. Thresholds should not be selected as design or continuous operation points.
    - Max. permissible discharge end temperature 140 °C
    - Max. permissible switching frequency 8x /h.
    - A minimum running time of 3 min. steady-state condition (continuous operation) must be achieved.
  - For operation with additional cooling:
    - Use only oils that are highly thermally stable.
    - Avoid continuous operation near the limits.
  - For operation with frequency converter:
    - The maximum current and power consumption must not be exceeded. In the case of operation above the mains frequency, the application limit can therefore be limited.
  - When operating in the vacuum range, there is a danger of air entering on the suction side. This can cause chemical reactions, a pressure rise in the condenser and an elevated compressed-gas temperature. Prevent the ingress of air at all costs!



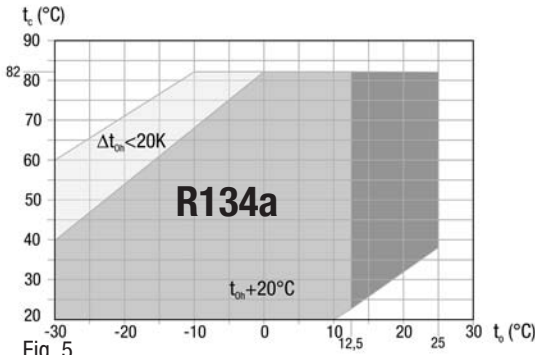

Fig. 5

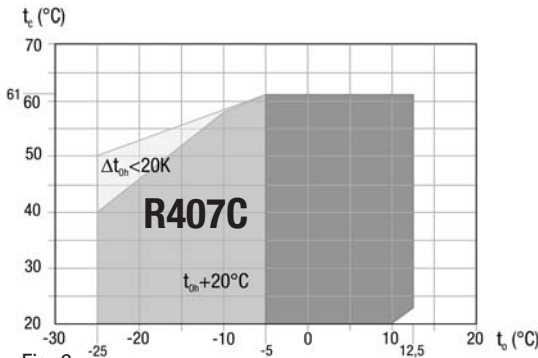

Fig. 6

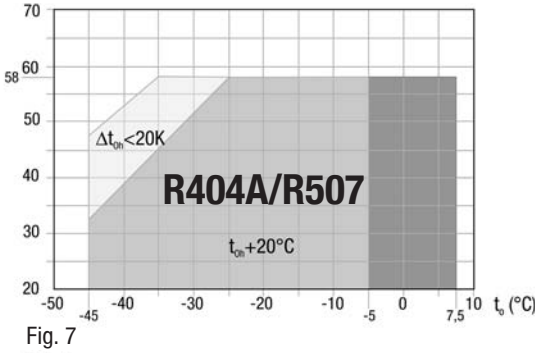

Fig. 7

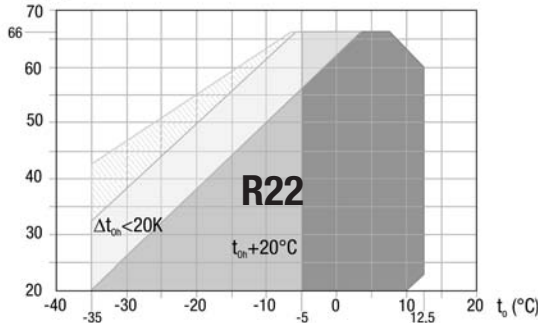





Fig. 8

-  Unlimited application range
-  Supplementary cooling or reduced suction gas temperature
-  Supplementary cooling and reduced suction gas temperature
-  Motor version S (more powerful motor)

$t_o$  Evaporation temperature (°C)

$t_c$  Condensing temperature (°C)

$\Delta t_{oh}$  Suction gas superheat (K)

$t_{oh}$  Suction gas temperature (°C)

**Max. permissible operating pressure (LP/HP)<sup>1)</sup>: 19/28 bar**

<sup>1)</sup> LP = Low pressure  
HP = High pressure

**Design for other areas on request**

# 4| Compressor assembly



## INFO!

**New compressors are factory-filled with inert gas (3 bar nitrogen). Leave this service charge in the compressor for as long as possible and prevent the ingress of air. Check the compressor for transport damage before starting any work.**

### 4.1 Setting up



- Use transport eyelet.
- Do not lift manually!
- Use lifting gear!

Fig. 9

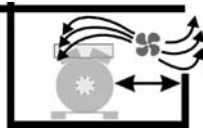

- Provide adequate clearance for maintenance work.
- Ensure adequate compressor ventilation.

Fig. 10



- Do not use in a corrosive, dusty, damp atmosphere or a combustible environment.

Fig. 11

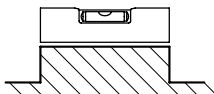

- Setup on an even surface or frame with sufficient load-bearing capacity.
- Single compressor preferably on vibration damper.
- Duplex and parallel circuits always rigid.

Fig. 12

### 4.2 Pipe connections



## ATTENTION!

- **Do not solder as long as the compressor is under pressure.**
- **Superheating can damage the valve. Remove the pipe supports therefore from the valve for soldering and accordingly cool the valve body during and after soldering.**
- **Only solder using inert gas to inhibit oxidation products (scale).**

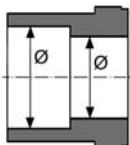

- The **pipe connections** have graduated inside diameters so that pipes with standart millimetre and inch dimensions can be used.
- The connection diameters of the shut-off valves are rated for maximum compressor output. **The actual required pipe cross section must be matched to the output. The same applies for non-return valves.**

Fig. 13: graduated internal diameter

# 4| Compressor assembly

## 4.3 Pipes

- Pipes and system components must be clean and dry inside and free of scale, swarf and layers of rust and phosphate. Only use air-tight parts.
- Lay pipes correctly. Suitable vibration compensators must be provided to prevent pipes being cracked and broken by severe vibrations.
- Ensure a proper oil return.
- Keep pressure losses to an absolute minimum.

## 4.4 Laying suction and pressure lines



**INFO!** Proper layout of the suction and pressure lines directly after the compressor is integral to the smooth running and vibration behaviour of the system.



**ATTENTION!** Improperly installed pipes can cause cracks and tears which can result in a loss of refrigerant,

**A rule of thumb:**

Always lay the first pipe section starting from the shut-off valve **downwards and parallel to the drive shaft**.

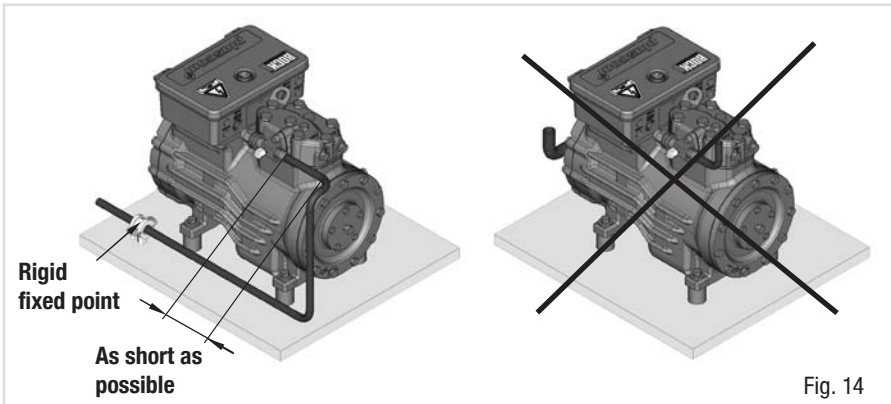

GB

# 4| Compressor assembly

## 4.5 Operating the shut-off valves

- Before opening or closing the shut-off valve, release the valve spindle seal by approx.  $\frac{1}{4}$  of a turn counter-clockwise.
- After activating the shut-off valve, re-tighten the adjustable valve spindle seal clockwise.

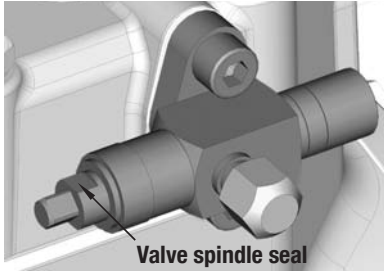

Fig. 15

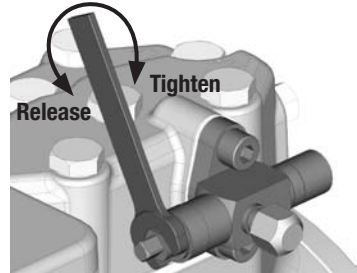
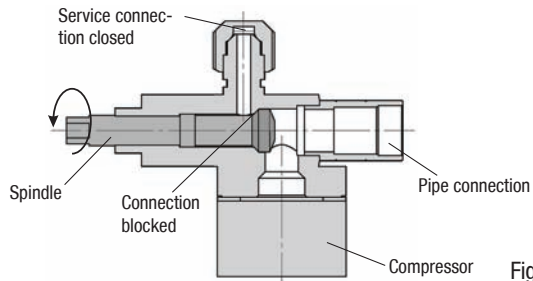

Fig. 16

## 4.6 Operating mode of the lockable service connections

GB



### Opening the shut-off valve:

Spindle: turn to the left (counter-clockwise) as far as it will go.

—> Shut-off valve completely opened / service connection closed.

Fig. 17

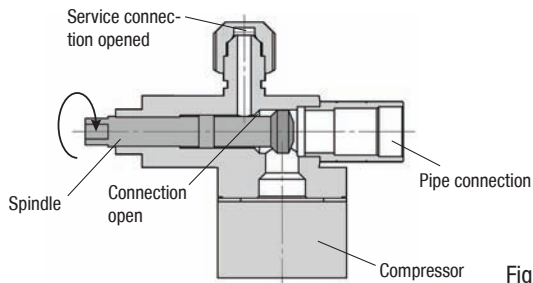

### Opening the service connection

Spindle: Turn  $\frac{1}{2}$  - 1 turn to the right clockwise.

—> Service connection opened / shut-off valve opened.

Fig. 18

09652-09.2013-DGbFEI

# 5| Electrical connection

## 5 Electrical connection



**DANGER!** High voltage! Risk of electric shock! Only carry out work when the electrical system is disconnected from the power supply!



**INFO!**

- Connect the compressor motor in accordance with the circuit diagram (see inside of terminal box).
- Use suitable cable entry point of the correct protection type (see name plate) for routing cables into the terminal box. Insert the strain reliefs and prevent chafe marks on the cables.
- Compare the voltage and frequency values with the data for the mains power supply. **Only connect the motor if these values are the same.**

### 5.1 Information for contactor and motor contactor selection

All protection equipment, switching and monitoring devices must comply with the local safety regulations and established specifications (e.g. VDE) and regulations as well as the manufacturer's specifications. **Motor protection switch is required!** Motor contactors, feed lines, fuses and motor protection switches must be rated according to the maximum operating current (see name plate).

Use the following overload protection device:

A current-dependent time-delayed overload protection device for monitoring of all three phases, not set higher than the rated current of the machine, which must respond at 1.2 times the set current within 2 hours and must not have responded at 1.05 times the set current within 2 hours, or another comparable device.

GB

### 5.2 Connection of the driving motor

The compressor is designed with a motor for star-delta circuits.

Designation on the name plate	Sticker on the terminal box
$\Delta / Y$	

Star-delta start-up is only possible on 230 V voltage supply. Example:

230 V $\Delta$		400 V Y
Direct start	Star-delta start	Direct start only



**INFO!** The connection examples shown refer to the standard version. In the case of special voltages, the instructions affixed to the terminal box apply.

### 5.3 Circuit diagramm for direct start 230 V $\Delta$ / 400 V Y

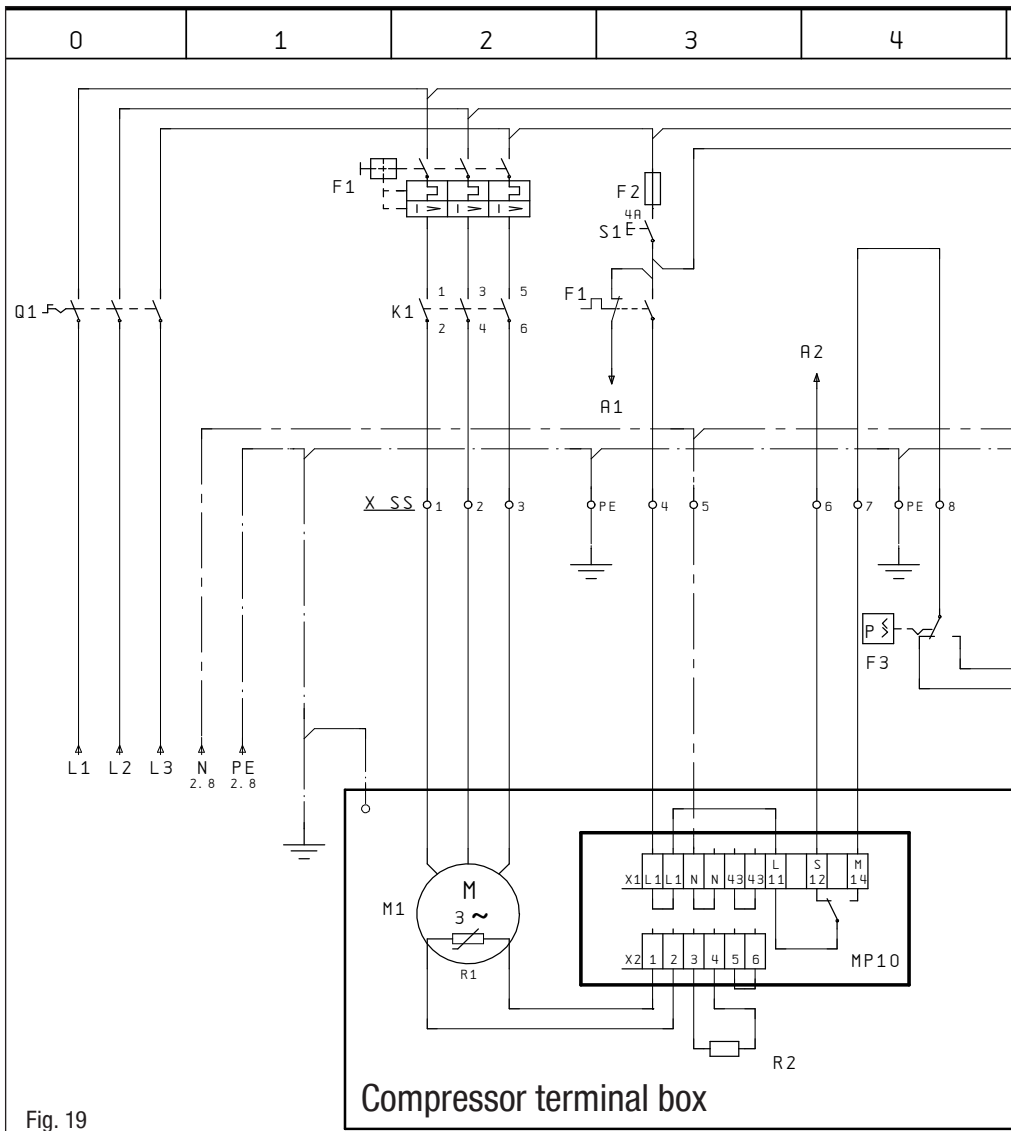
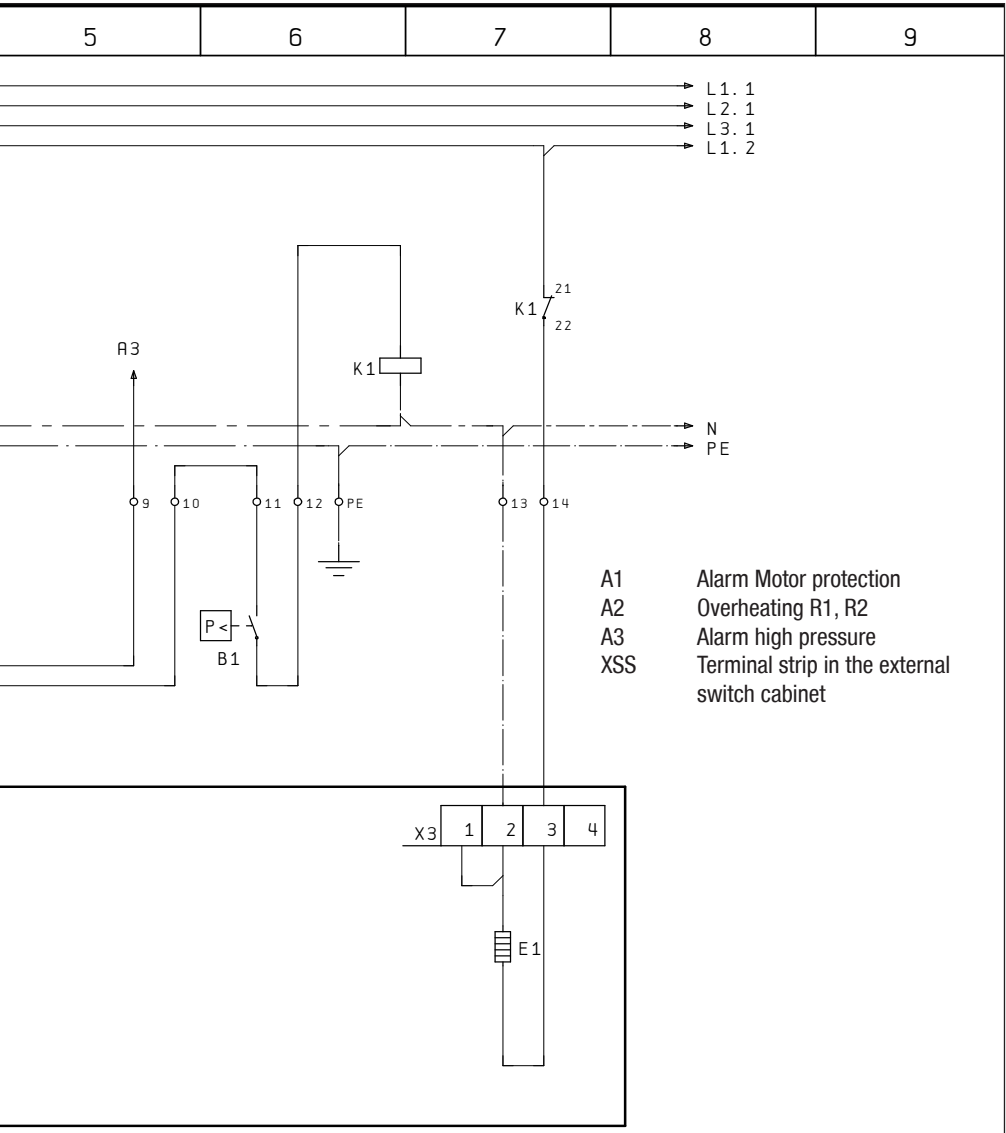

Fig. 19

R1	Cold conductor PTC sensor motor winding
R2	Thermal protection thermostat (PTC sensor)
F1	Load circuit safety switches
F2	Control power circuit fuse
F3	Safety chain (high/low pressure monitoring)
B1	Release switch (thermostat/pressostat)
Q1	Main switch

09652-09.2013-DG6FEI



**GB**

09652-09.2013-DGbFEI

S1	Control voltage switch
M1	Compressor motor
K1	Compressor contactor
MP10	Electronic trigger unit MP 10
E	Oil sump heater
X3	Terminal strip in terminal box
XSS	Terminal strip in the external switch cabinet

# 5| Electrical connection

## 5.4 Start unloader

To avoid current peaks during the starting phase we recommend using the Bock-ESS soft starting device (Electronic Soft Start). Refer to "Accessories" for further information.

## 5.5 Electronic trigger unit MP 10

The compressor motor is fitted with cold conductor temperature sensors (PTC) connected to the electronic trigger unit MP 10 in the terminal box. Readiness to operate is signalled by the H3 LED (green) after the power supply is applied. In the case of excess temperature in the motor winding, the unit switches off the compressor and the H1 LED lights red.

The hot gas side of the compressor can also be protected against overtemperature using a thermal protection thermostat (accessory). The H2 LED (red) is provided for the protection function.

**The unit trips when an overload or inadmissible operating conditions occur. Find and remedy the cause.**



**INFO!** The unit has a restart prevention device. After you have rectified the fault, interrupt the mains voltage. This unlocks the restart prevention device and the LEDs H1 and H2 go out.

## 5.6 Connection of the trigger unit MP10



**INFO!** Connect the trigger unit MP10 in accordance with the circuit diagram. Protect the trigger unit with a delayed-action fuse (F) of max. 4 A. In order to guarantee the protection function, install the trigger unit as the first element in the control power circuit.

Temperature monitoring connections:

- Motor winding: Terminals 1 - 2
- Thermal protection thermostat: Terminals 3 - 4
- Restart prevention: Terminals 5 - 6



**ATTENTION!** Terminals 1 - 6 on the trigger unit MP 10 and terminals PTC 1 and PTC 2 on the compressor terminal board must not come into contact with mains voltage. This would destroy the trigger unit and PTC sensors. The supply voltage at L1-N (+/- for DC 24 V version) must be identical to the voltage at terminals 11, 12, 14 and 43.

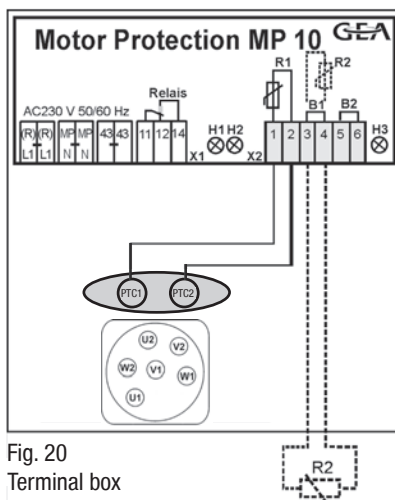

Fig. 20  
Terminal box



## 5| Electrical connection

### 5.7 Function test of the trigger unit MP 10

Before start-up, troubleshooting or making changes to the control power circuit, check the functionality of the trigger unit:

Pos	Procedure	LED H1 red	LED H2 red	LED H3 green
1	<ul style="list-style-type: none"><li>• <b>Interrupt power supply (L1 or S1)</b></li><li>• Release the motor temperature sensor connection (1 or 2)</li><li>• Release the hot gas temperature sensor (if installed) (3 or 4)</li></ul>	OFF	OFF	OFF
2	<ul style="list-style-type: none"><li>• <b>Restore the power supply (L1 or S1)</b></li><li>• Function check of motor temperature sensor: operational</li><li>• Function check of hot gas temperature sensor: operational</li></ul>	ON	ON	ON
3	<ul style="list-style-type: none"><li>• <b>Interrupt power supply again (L1 or S1)</b></li><li>• Reconnect terminals 1 or 2 and/or 3 or 4</li></ul>	OFF	OFF	OFF
4	<ul style="list-style-type: none"><li>• <b>Restore the power supply (L1 or S1):</b></li><li>• MP 10 is operational again</li></ul>	OFF	OFF	ON

The compressor and the trigger unit MP10 are operational when the H3 LED (green) lights.

GB

# 6| Commissioning

## 6.1 Preparations for start-up



**INFO!**

In order to protect the compressor against inadmissible operating conditions, high-pressure and low-pressure pressostats controls are mandatory on the installation side.

The compressor has undergone trials in the factory and all functions have been tested. There are therefore no special running-in instructions.

**Check the compressor for transport damage!**

## 6.2 Pressure strength test



**DANGER!**

**Bursting! The compressor must only be pressurised using nitrogen (N<sub>2</sub>). Never pressurise with oxygen or other gases!**

**The maximum permissible overpressure of the compressor must not be exceeded at any time during the testing process (see name plate data)! Do not mix any refrigerant with the nitrogen as this could cause the ignition limit to shift into the critical range.**

The compressor has been factory-tested for pressure resistance. The following must be observed if the entire plant is subjected to an additional pressure strength test:

- Test the refrigeration circuit according to EN 378-2 or a corresponding safety standard.

## 6.3 Leak test



**DANGER!**

**Bursting!**

**Do not mix any refrigerant with the nitrogen (N<sub>2</sub>) as this could cause the ignition limit to shift into the critical range.**

- Carry out the leak test of the refrigerating system in accordance with EN 378-2 or a corresponding safety standard **without including the compressor.**

## 6.4 Evacuation



**ATTENTION! Do not start the compressor if it is under vacuum. Do not apply any voltage - even for test purposes (must only be operated with refrigerant).**

Under vacuum, the spark-over and creepage current distances of the terminal board connection bolts shorten; this can result in winding and terminal board damage.

- First evacuate the **system** and then include **the compressor in the evacuation process.**
- Relieve the compressor pressure.
- Open the suction and pressure line shut-off valves.
- Evacuate the suction and discharge pressure sides using the vacuum pump.
- At the end of the evacuation process, the vacuum should be < 1.5 mbar when the pump is switched off.
- Repeat this process as often as is required.

# 6| Commissioning

## 6.5 Refrigerant charge



**CAUTION!** Wear personal protective clothing such as goggles and protective gloves!

- Make sure that the suction and pressure line shut-off valves are open.
- With the compressor switched off, add the liquid refrigerant directly to the condenser or receiver, breaking the vacuum.
- If the refrigerant needs topping up after starting the compressor, it can be topped up in vapour form on the suction side, or, taking suitable precautions, also in liquid form at the inlet to the evaporator.



**INFO!**

- **Avoid overfilling the system with refrigerant!**
- **In order to prevent shifts in concentration, zeotropic refrigerant blends (e.g. R407C) must always only be added to the refrigerating system in liquid form.**
- **Do not pour liquid refrigerant through the suction line shut-off valve on the compressor.**
- **It is not permissible to mix additives with the oil and refrigerant.**

## 6.6 Start-up



**WARNING!** Ensure that both shut-off valves are open before starting the compressor!

- Check that the safety and protection devices (pressure switch, motor protection, electrical contact protection measures, etc.) are functioning properly.
- Switch on the compressor and let it run for at least 10 minutes.
- Check the **oil level**: The oil must be visible in the sight glass.



**ATTENTION!** If larger quantities of oil have to be topped up, there is a risk of oil impact effects. If this is the case, check the oil return!

## 6.7 Avoid slugging



**ATTENTION!** Slugging can result in damage to the compressor and cause refrigerant to leak.

### To prevent slugging:

- The complete refrigeration plant must be properly designed.
- All components must be compatibly rated with each other with regard to output (particularly the evaporator and expansion valves).
- Suction gas superheating at the compressor input **should be min. 7 - 10 K** (check the setting of the expansion valve).
- The system must reach a state of equilibrium.
- Particularly in critical systems (e.g. several evaporator points), measures such as the use of liquid traps, solenoid valve in the liquid line, etc. are recommended.

**There should be no movement of refrigerant in the compressor while the system is at a standstill.**

# 6 | Commissioning

## 6.8 Connection of oil level regulator

The connection "O" is provided for installing an oil level regulator. A corresponding adapter must be obtained from the trade.

# 7 | Maintenance

## 7.1 Preparation



**WARNING!** Before starting any work on the compressor:

- Switch off the compressor and secure it to prevent a restart.
- Relieve compressor of system pressure.
- Prevent air from infiltrating the system!

After maintenance has been performed:

- Connect safety switch.
- Evacuate compressor.
- Release switch-on lock.

GB

## 7.2 Work to be carried out

In order to guarantee optimum operational reliability and service life of the compressor, **we recommend** carrying out servicing and inspection work at regular intervals:

- **Oil change:**
  - not mandatory for factory-produced series systems.
  - for field installations or when operating near the application limit: for the first time after 100 to 200 operating hours, then approx. every 3 years or 10,000 - 12,000 operating hours. Dispose of used oil according to the regulations; observe national regulations.
- **Annual checks:** Oil level, leak tightness, running noises, pressures, temperatures, function of auxiliary devices such as oil sump heater, pressure switch.

## 7.3 Spare parts recommendation

HG12P / ...	60-4 S	75-4 (S)	90-4 (S)	110-4 (S)
Designation	Ref. No.	Ref. No.	Ref. No.	Ref. No.
Set of gaskets			80339	
Valve plate kit		80352		80353
Oil pump kit			08324	

**Only use genuine Bock spare parts!**

09652-09.2013-DG6FEI

# 7| Maintenance

## 7.4 Accessories

Available accessories can be found on the Internet at [www.bock.de](http://www.bock.de).

## 7.5 Extract from the lubricants table

The oil type filled as standard in the factory is marked on the **name plate**. **This oil type should be used as a preference.** Alternatives are stated in the extract from our lubricants table below.

Refrigerants	Bock standard oil types	Recommended alternatives
<b>HFC</b> (e.g. R134a, R407C, R404A)	<b>Fuchs Reniso Triton SE 55</b>	Fuchs Reniso Triton SEZ 32 Esso/Mobil EAL Arctic 46 Sunoco Suniso SL 46 Texaco Capella HFC 55
<b>HCFC</b> (e.g. R22)	<b>Fuchs Reniso SP 46</b>	Fuchs Reniso SP 32 BP Energol LPT 46 Sunoco Suniso 3,5 GS Texaco Capella WF 46

## 7.6 Decommissioning

Close the shut-off valves on the compressor. Drain the refrigerant (it must not be discharged into the environment) and dispose of it according to the regulations. When the compressor is depressurised, undo the fastening screws of the shut-off valves. Remove the compressor using an appropriate hoist. Dispose of the oil inside in accordance with the applicable national regulations.

**GB**

## 8 | Technical data

Type	No. of cylinders	Displacement 50 / 60 Hz (1450 / 1740 rpm)	Electrical data ③			Weight	Connections ④		Oil charge	Sound pressure level
			Voltage ①	Max. Operating current ② $\Delta / Y$	Max. power consumption ②		Starting current (rotor locked) $\Delta / Y$	Discharge line DV		
HG12P/60-4 S		m <sup>3</sup> /h	A	kW	A	kg	mm (inch)	mm (inch)	Ltr.	L / M / H ⑤
		5,4 / 6,4	6,8 / 3,9	2,2	40 / 23	48				58,5 / 58 / 57
HG12P/75-4		6,7 / 8,1	7,1 / 4,1	2,3	40 / 23	48				59 / 58,5 / 58
HG12P/75-4 S		6,7 / 8,1	8,0 / 4,6	2,6	43 / 25	49				59 / 58,5 / 58
HG12P/90-4	2	8,0 / 9,6	8,5 / 4,9	2,8	43 / 25	49	12 (1/2)	16 (5/8)	0,8	59,5 / 59 / 58
HG12P/90-4 S		8,0 / 9,6	8,8 / 5,1	2,9	45 / 26	49				59,5 / 59 / 58
HG12P/110-4		9,4 / 11,3	9,2 / 5,3	3,1	43 / 25	49				60 / 59 / 58
HG12P/110-4 S		9,4 / 11,3	10,6 / 6,1	3,6	45 / 26	49				60 / 59 / 58

① Tolerance ( $\pm$  10%) relative to the mean value of the voltage range.  
Other voltages and types of current on request.

② - The specifications for max. power consumption apply for 50Hz operation.  
For 60Hz operation, the specifications have to be multiplied by the factor 1.2. The max. working current remains unchanged.

- Take account of the max. operating current / max. power consumption for design of fuses, supply lines and safety devices. Fuse: Consumption category AC3

③ All specifications are based on the average of the voltage range

④ For solder connections

⑤ **L** = low temperature ( $-35 / 40$  °C), **M** = normal cooling ( $-10 / 45$  °C),  
**H** = air conditioning ( $5 / 50$  °C) sound pressure level measured in low reflection measuring area, measuring distance 1m.

Compressor operation at 50 Hz (1450 rpm), refrigerant R404A.  
Values stated are average values, tolerance  $\pm$  2 dB(A).

## 9| Dimensions and connections

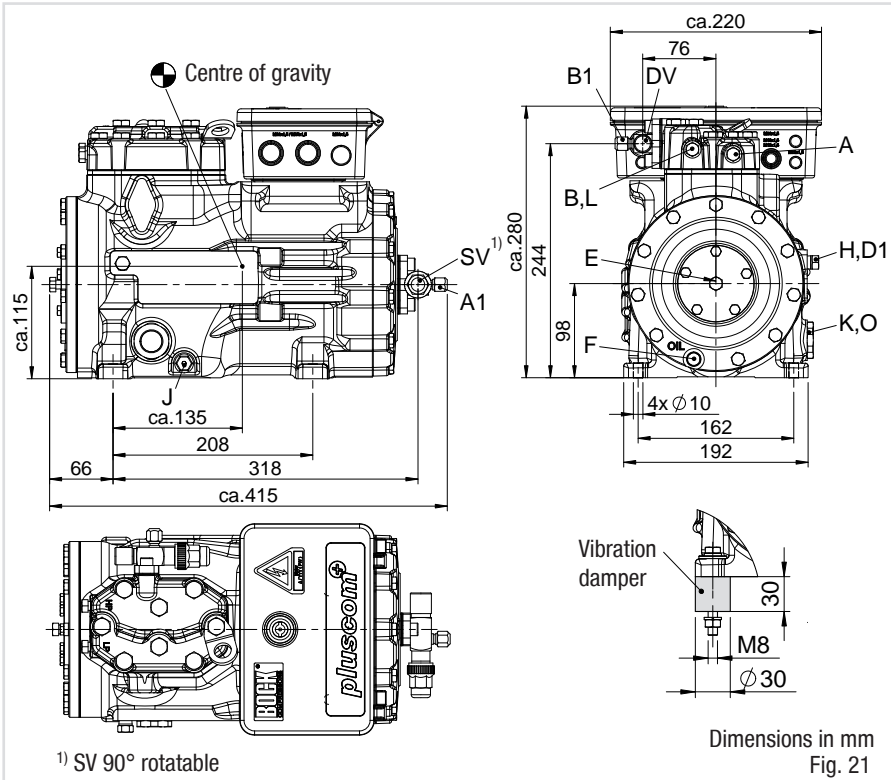

GB

SV	Suction line	see technical data, Chapter 8	
DV	Discharge line		
A	Connection suction side, not lockable		1/8" NPTF
A1	Connection suction side, lockable		7/16" UNF
B	Connection discharge side, not lockable		1/8" NPTF
B1	Connection discharge side, lockable		7/16" UNF
D1	Connection oil return from oil separator		1/4" NPTF
E	Connection oil pressure gauge		1/8" NPTF
F	Oil drain		M8
H	Oil charge plug		1/4" NPTF
J	Connection oil sump heater		Ø 15 mm
K	Sight glass		1 1/8" - 18 UNEF
L	Connection thermal protection thermostat		1/8" NPTF
O	Connection oil level regulator		1 1/8" - 18 UNEF

# 10| Declaration of conformity and installation

## DECLARATION OF CONFORMITY CE 04

for using the compressors within the European Union  
(in accordance with Low Voltage Directive 2006/95/EC)

We hereby declare that the following refrigerating compressors

Product designation: **HG12P**

comply with the Low Voltage Directive 2006/95/EC.

Applied harmonised standard:

EN 60034-1:2010

EN 60204-1:2006

## DECLARATION OF INSTALLATION

for using the compressors within the European Union  
(in accordance with Machinery Directive 2006/42/EC)

The manufacturer: GEA Bock GmbH, Benzstraße 7  
72636 Frickenhausen, Tel.: 07022/9454-0

hereby declares that the refrigerating compressor **HG12P** complies with the basic requirements of Appendix II 1B of the Machinery Directive 2006/42/EC.

Applied harmonised standard:

EN 12693:2008 and the corresponding standards referenced

A partly completed machine may only be put into operation when it has been established that the machine, into which the partly completed machine is to be installed, conforms to the regulations of the Machinery Directive (2006/42/EC).

The manufacturer undertakes to transmit electronically the special documentation required by individual states for partly completed machinery on request.

The special technical documentation required for partly completed machinery has been created in accordance with Appendix VII Part B.

Person responsible for documentation is: Wolfgang Sandkötter, Benzstraße 7, 72636 Frickenhausen.

Frickenhausen, 01.11.2011



ppa. Wolfgang Sandkötter,  
Chief Development Officer



# 11| Service

Dear customer,

Bock compressors are top-quality, reliable and service-friendly quality products.

If you have any questions about installation, operation and accessories, please contact our technical service or specialist wholesaler and/or our representative. The Bock service team can be contacted by phone with a **toll-free hotline 00 800 / 800 000 88** or via **e-mail: [bock@gea.com](mailto:bock@gea.com)**.

Yours faithfully

**GEA Bock GmbH**

**Benzstraße 7**

**72636 Frickenhausen**

**Germany**

We also provide information on the Internet at **[www.bock.de](http://www.bock.de)**.

For example, under the "Documentation" link you will find:

- Technical information
- Product information
- Product brochures
- and much more

**GB**



*We live our values.*

Excellence • Passion • Integrity • Responsibility • GEA-versity

GEA Group is a global engineering company with multi-billion euro sales and operations in more than 50 countries. Founded in 1881, the company is one of the largest providers of innovative equipment and process technology. GEA Group is listed in the STOXX® Europe 600 index.

## **GEA Refrigeration Technologies**

**GEA Bock GmbH**

Benzstraße 7, 72636 Frickenhausen, Germany  
Telephone: +49 7022 9454-0, Fax: +49 7022 9454-137  
bock@gea.com, www.bock.de